

OV4688 4MP product brief



Native 16:9 HD 4-Megapixel CameraChip™ Sensor with High Frame Rate and Excellent Low Light Sensitivity for Next-Generation Video Applications



available in a lead-free package

The OV4688 is a high-performance 4-megapixel CameraChip sensor in a native 16:9 high definition (HD) format designed to deliver ultra-high quality fast frame rate HD video for mobile devices. Built on a new 2-micron OmniBSI-2™ pixel, the OV4688 offers best-in-class low-light performance with a 40 percent increase in sensitivity compared to the 1.75-micron OmniBSI-2 pixel.

The OV4688 supports timing for two High Dynamic Range (HDR) modes, frame-based sequential HDR and line-based staggered HDR. A major advantage of staggered mode over sequential mode is a significant reduction of motion artifacts in the captured images. The sensor's enhanced performance, along with its ability to record full resolution 4MP @ 90 frames per second (fps), allows it to capture best-in-class video and high-speed photography with zero shutter lag, and video HDR at 30 fps.

The 1/3-inch OV4688 can also capture 1080p HD at 120 fps with electronic image stabilization (EIS), or 720p HD at 180 fps. The OV4688's high frame rates enable additional key benefits, including full-resolution continuous frame capture or burst photography and recording of high-quality slow-motion video.

The OV4688 features a high-speed 4-lane MIPI serial output interface to facilitate the required high data transfer rate and fits into an 8.5 x 8.5 mm module with a z-height of about 5 mm.

Find out more at www.ovt.com.



Applications

- Cellular Phones
- Digital Video Camcorders (DVC)
- Digital Still Cameras (DSC)
- PC Multimedia

Product Features

- supports staggered, sequential HDR timing
- automatic black level calibration (ABLC)
- programmable controls for frame rate, mirror and flip, cropping, and windowing
- static defective pixel canceling
- supports output formats: 10-bit RAW RGB (MIPI)
- supports horizontal and vertical subsampling
- supports images sizes: 4MP, 3MP, EIS1080p, 1080p, EIS720p
- fast mode switching
- support 2x2 binning, 4x4 binning, re-sampling filter
- standard serial SCCB interface
- up to 4-lane MIPI serial output interface
- embedded 1.5K bits one-time programmable (OTP) memory for part identification, etc
- two on-chip phase lock loops (PLLs)
- programmable I/O drive capability
- built-in temperature sensor

OV4688



Ordering Information

- OV04688-G04A-Z**
(color, chip probing, 200 μm backgrinding, reconstructed wafer with good die)

Product Specifications

- active array size:** 2688 x 1520
- max S/N ratio:** 38.3 dB
- power supply:**
 - core: 1.1 - 1.3V
 - analog: 2.6 - 3.0V
 - I/O: 1.7 - 3.0V
- power requirements:**
 - active: 163 mA (261 mW)
 - standby: 1 mA
 - XSHUTDOWN: <math><10 \mu\text{A}</math>
- temperature range:**
 - operating: -30°C to +85°C junction temperature
 - stable image: 0°C to +60°C junction temperature
- output formats:** 10-bit RAW RGB data
- lens size:** 1/3"
- input clock frequency:** 6 - 64 MHz
- lens chief ray angle:** 31.5° non-linear
- dynamic range:** 64.6 dB @ 1x gain
- maximum image transfer rate:**
 - 2688x1520: 90 fps
 - 1920x1080: 120 fps
 - 1280x720: 180 fps
 - 672x380: 330 fps
- sensitivity:** 1900 mV/lux-sec
- scan mode:** progressive
- maximum exposure interval:** 1548 x T_{ROW}
- pixel size:** 2 μm x 2 μm
- dark current:** 4 mV/sec @ 60°C junction temperature
- image area:** 5440 μm x 3072 μm
- die dimensions:**
 - COB: 6600 μm x 5800 μm

Functional Block Diagram

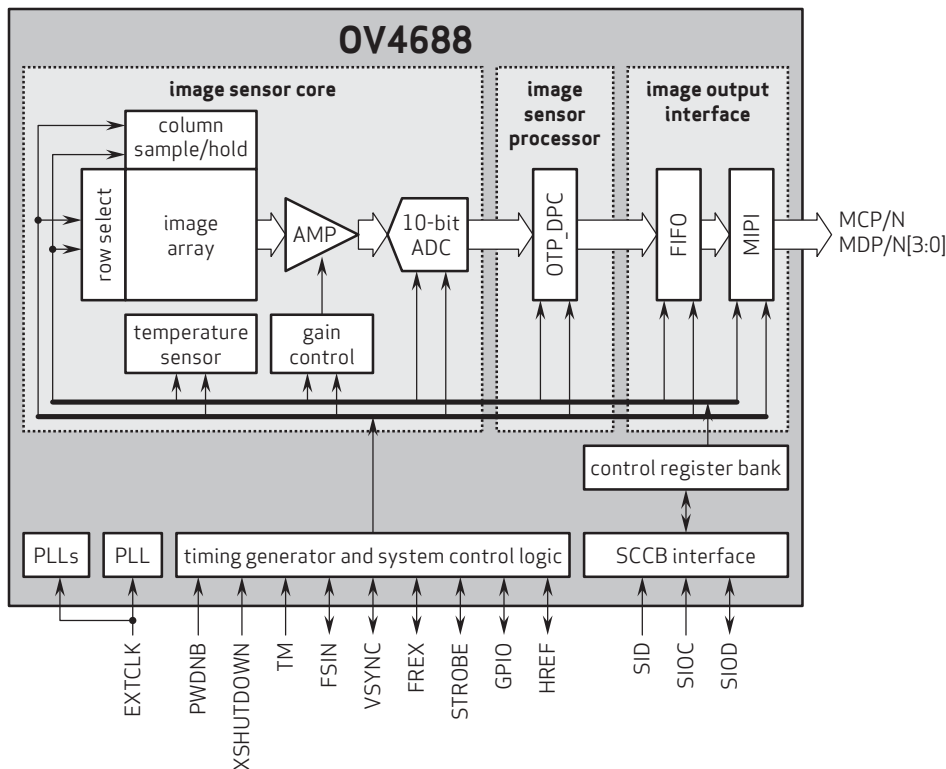

4275 Burton Drive
Santa Clara, CA 95054
USA

Tel: +1 408 567 3000
Fax: +1 408 567 3001
www.ovt.com

OmniVision reserves the right to make changes to their products or to discontinue any product or service without further notice. OmniVision and the OmniVision logo are registered trademarks of OmniVision Technologies, Inc. CameraChip and OmniBSI-2 are trademarks of OmniVision Technologies, Inc. All other trademarks are the property of their respective owners.



OmniVision