

THIS DOCUMENT IS THE PROPERTY OF KEYSTONE ELECTRONICS CORP. AND SHALL NOT BE REPRODUCED, DISTRIBUTED OR USED AS A BASIS FOR MANUFACTURE WITHOUT PRIOR WRITTEN PERMISSION FROM KEYSTONE ELECTRONICS CORP.

**ACTUAL SIZE**

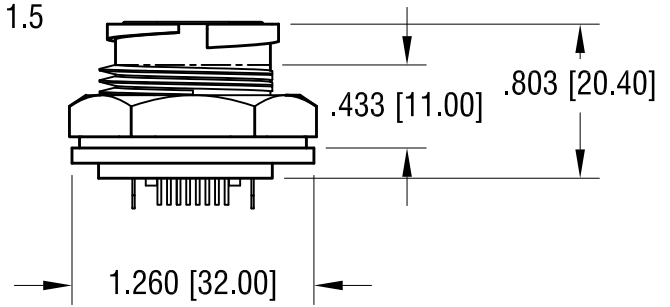
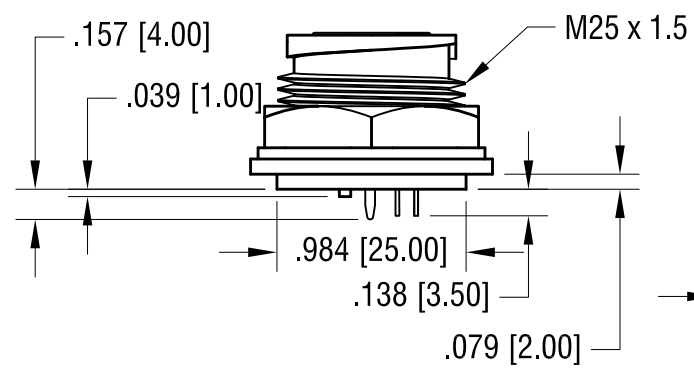
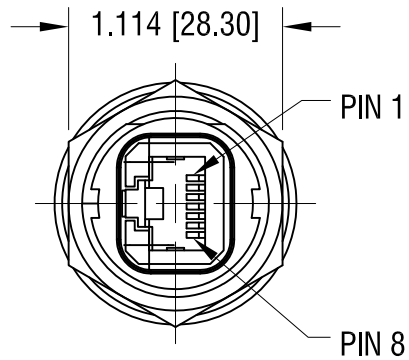
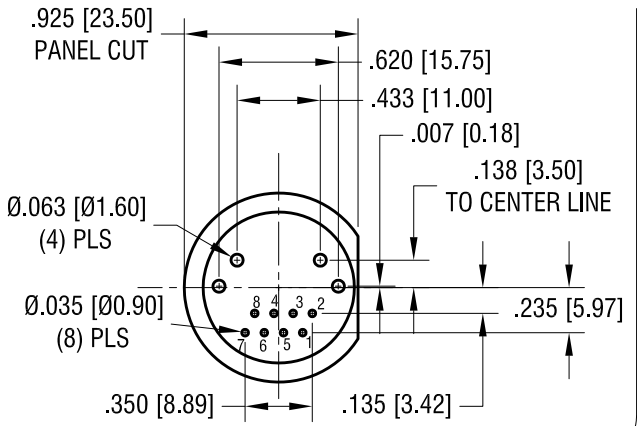
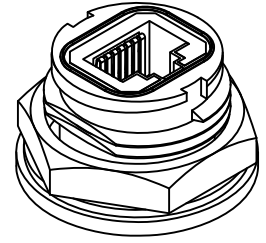

**NOTE:**

1. HOUSING: MAT'L- HIGH. TEMP.. THERMOPLASTIC  
UL 94V-0
2. CONTACT: MAT'L- PHOSPHOR BRONZE  
FINISH ON SOLDER AREA: TIN PLATE, OVER NICKEL  
FINISH ON CONTACT AREA: GOLD PLATE, OVER NICKEL

**KEYSTONE ELECTRONICS CORP.**

www.keyelco.com • NEW HYDE PARK, NY 11040 • Tel (516) 328-7500

PART NAME		WATER PROOF KEYSTONE JACK	
MATERIAL		AS NOTED	
FINISH	AS NOTED	DRN BY	NT
		APP'D	LN
		DATE	4.04.16
		SCALE	1X
TOLERANCES	INCH [MM]	CODE	DWG NO.
DECIMAL	± .005 [± 0.13]	C	960
ANGULAR	± 1°		
UNLESS OTHERWISE SPECIFIED			

DATE	DESCRIPTION	REV.