

## 500-1500W Industrial Power supplies

<https://product.tdk.com/en/power/lzsa>  
[www.emea.lambda.tdk.com/lzsa](http://www.emea.lambda.tdk.com/lzsa)



Industrial



COTS



Test



COMM



Broadcast

The LZSA series offers a unique feature set not commonly found with standard off-the-shelf supplies. Compliance to the MIL-STD-810E standards for shock and vibration and board coating make the LZSA power supplies ideal for use in a variety of harsh environment applications. They also comply with the tough ring wave lightning surge test per IEEE C62.41. Features include remote on/off, remote sense, frequency synchronization and a wide operating temperature range of -40°C to +71°C. The series also has a wide adjustment range which can be programmed using an external voltage or resistance.

Features	Benefits
• Rugged Mechanical Design With Coating on PCBs	• High Reliability in Harsh Environments
• Superior Thermal Design	• Long Life Even at 71°C Operation
• Wide Range, Programmable Output Adjustment	• Reduces The Need For custom Outputs
• Input Voltage Transient Protection	• Reduced System Filtering

Model Selector				
Model	Nominal Output Voltage (V)	Adjustment Range (V)	Maximum Current (A)	Maximum Power (W)
LZSA-1000-2	12	10 - 15.75	84	1008
LZSA-500-3	24	18 - 29.4	21	504
LZSA-1000-3	24	18 - 29.4	42	1008
LZSA-1500-3-001	24	18 - 29.4	63	1512 (3)
LZSA-1500-4	48	36 - 56	31.5	1512 (3)

Specification				
Model		LZSA500	LZSA1000	LZSA1500
<b>Input</b>				
Input Voltage Range	-	85 - 265Vac / 100-380Vdc (1)		
Input Frequency (2)	Hz	47-440Hz (2)		
Input Current Maximum (100Vac)	A	8	15	18
Inrush Current (110 / 220Vac)	A	25 / 45	30 / 40	
Leakage Current	uA	<500 at 265Vac, 60Hz		
Power Factor	-	EN61000-3-2 Class A		
Harmonics	-	EN61000-3-2 Compliant		
Hold Up Time at 110Vac Input	ms	20ms hold up, 20ms ride through		
Efficiency (Typical)	-	84%		
Emissions	-	EN55032/EN55011 Class B, EN61000-3-3, MIL STD 461/462D, CE102		
Immunity	-	See Immunity Table		
Line Dip	-	SEMI F47 Compliant (4)		
Safety Agency Certifications	-	IEC/EN/UL/CSA62368-1, 60950-1, UL508, CE Mark, SEMIF47 (>100Vac)		

Immunity				
Test	Standard	Test Level	Criteria	Notes
ESD	IEC 61000-4-2	±8kV air discharge, ±6kV contact discharge	B	See test report on website
Radiated Susceptibility	IEC 61000-4-3	10V/m, 80 - 1000MHz (80% AM at 1kHz)	A	
Electrical Fast Transient Burst	IEC 61000-4-4	AC line pulses of ±2 kV; I/O line pulses of ±2kV>3m	A	
Surge	IEC 61000-4-5	±2kV common mode, ±1kV differential mode	A	
Conducted Susceptibility	IEC 61000-4-6	10Vrms, 150kHz - 80 MHz 1kHz 80% AM	A	
Magnetic fields	IEC 61000-4-8	30Arms/m @ 50Hz	A	
Voltage Dips and Input Interruptions	IEC 61000-4-11	Voltage Dips of 30%, 60% and 100%; Interruptions of >95%	A & B	
Ring Wave	IEEE C62.41	6kV/30 ohms	A	

Specification		LZSA500	LZSA1000	LZSA1500
<b>Output</b>				
Line Regulation	%		0.10	
Load Regulation	%		0.10	
Transient Response	-	±1% deviation, recovering to ±0.2% in <1.25ms (25% load change)		
Temperature Coefficient	ppm/°C		100	
Ripple & Noise (pk-pk) (max.)	mV	75	75	24V: 75, 48V: 150
Minimum Load	A		None	
Overcurrent Protection	%		110-130	
Overvoltage Protection	-		User adjustable from front panel	
Overtemperature Protection	-		Internal thermostat. Cycle AC to reset.	
Remote Sense	-		Compensates for a total of 1V cable drop	
Remote On/Off	-		TTL compatible, active high	
Remote Adjust	-		Using front panel potentiometer, Resistance (1kV), or Voltage (1V/V)	
Input Power Good	-		Opto coupled, conducts up to 1mA @ <0.4V when active	
DC Good	-		Opto coupled, conducts up to 1mA @ <0.4V when active	
Inverter good	-		Opto coupled, conducts up to 1mA @ <0.4V when active	
Synchronization (Sync)	-		Auxiliary signal at approximately 200kHz used for synchronizing with other equipment.	
Indicators	-		Green LED indicates output good; red LED indicates overvoltage, overtemperature, or overcurrent	
Parallel Operation	-		Single wire current share	
Series Operation	-		See Installation Manual	
<b>Environmental</b>				
Operating Temperature	°C	-40 to +71, derate linearly to 60% load from 60 - 71° (A 20 minute warm up period needed for <30°)		
Storage Temperature	°C	-40 to +85		
Humidity (non condensing)	%RH	10 - 90		
Cooling	-	Variable speed, ball bearing fan		
Altitude	m	3,000m operating, 12,000m non operating		
Withstand Voltage	VDC	Input to Ground 2,121, Input to Output 4,242, Output to Ground 500		
Vibration	-	MIL-STD-810E, Method 514.4, Category 1, 9		
Shock	-	MIL-STD-810E, Method 516.4, Procedure I, II, IV, VI		
<b>Other</b>				
Weight (Typ)	lbs / kg	6.6 / 2.95	8.1 / 3.7	
Size (WxHxD) (excluding bus bars)	mm	108 x 121 x 260	143 x 121 x 267	
Size (WxHxD) (excluding bus bars)	Inches	4.25 x 4.75 x 10.25	5.62 x 4.75 x 10.5	
MTBF - Bellcore	Hours	132,958	99,039	99,039
Warranty	Years		5	

**Notes**

- (1) Startup >110VDC
- (2) Reduced power factor above 63Hz
- (3) 1512W @ 180-265VAC, 1200W @ 120VAC, 1104W @ 100VAC, 1008W @ 85VAC
- (4) See website for detailed specifications, test methods and installation manual

## Derating Charts

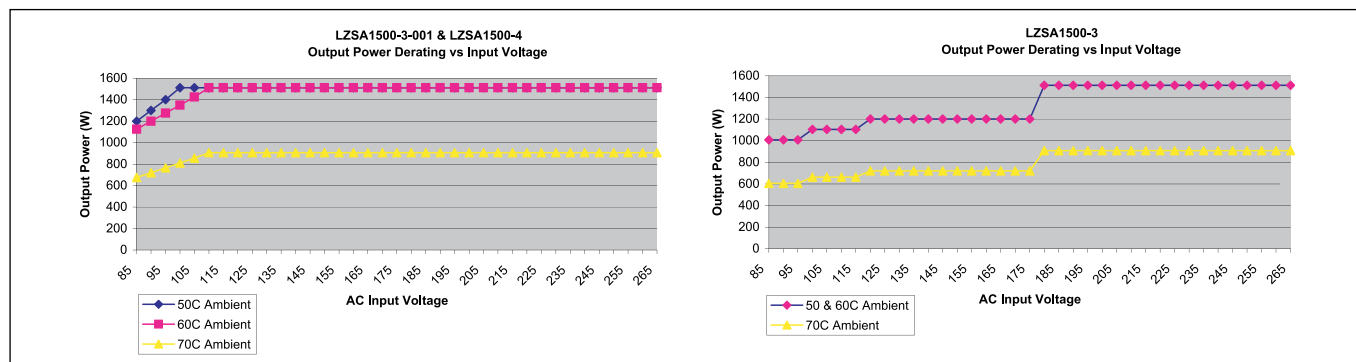

**LZSA 500 Outline Drawing**

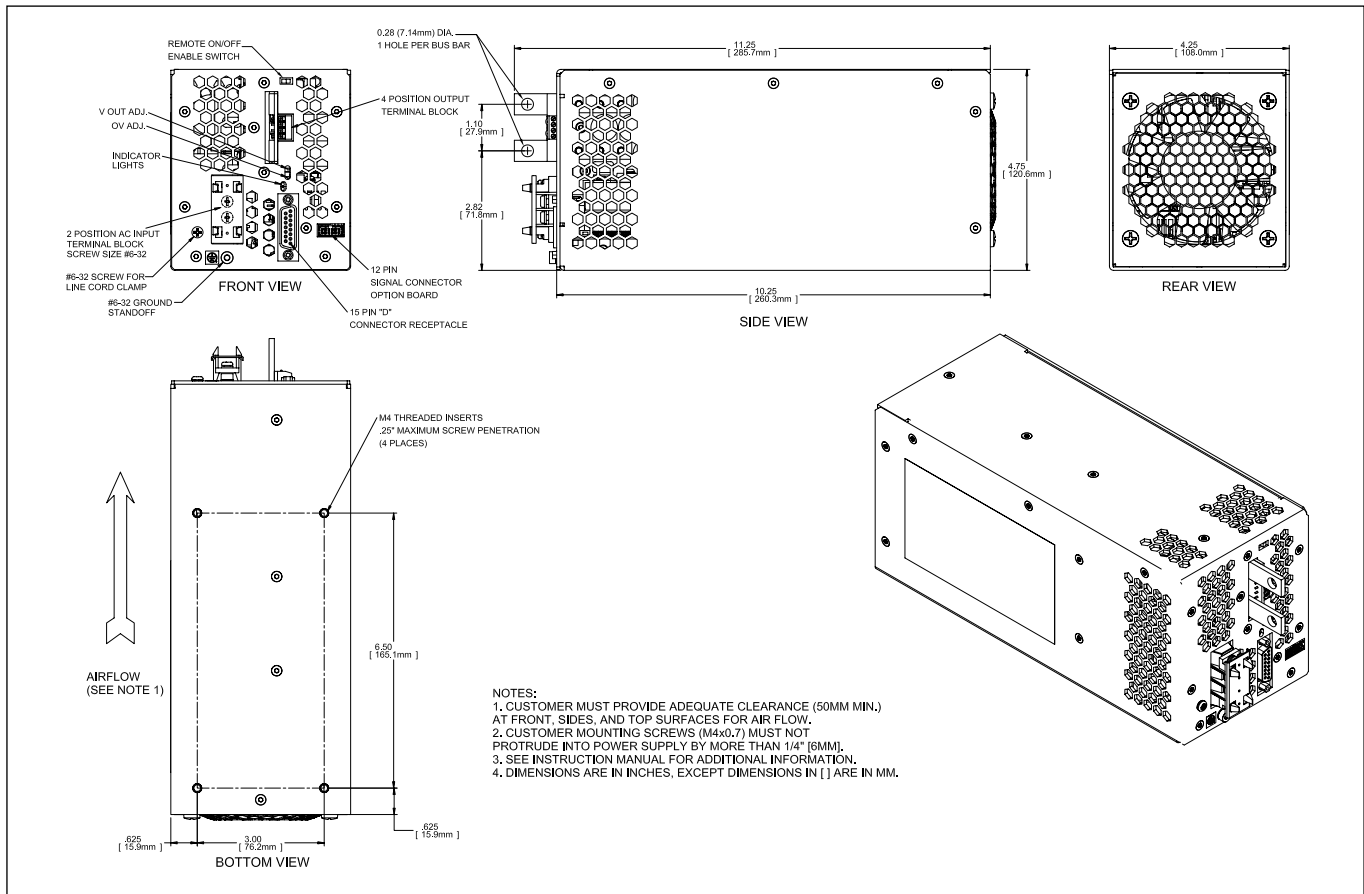

**LZSA 1000 Outline Drawing**

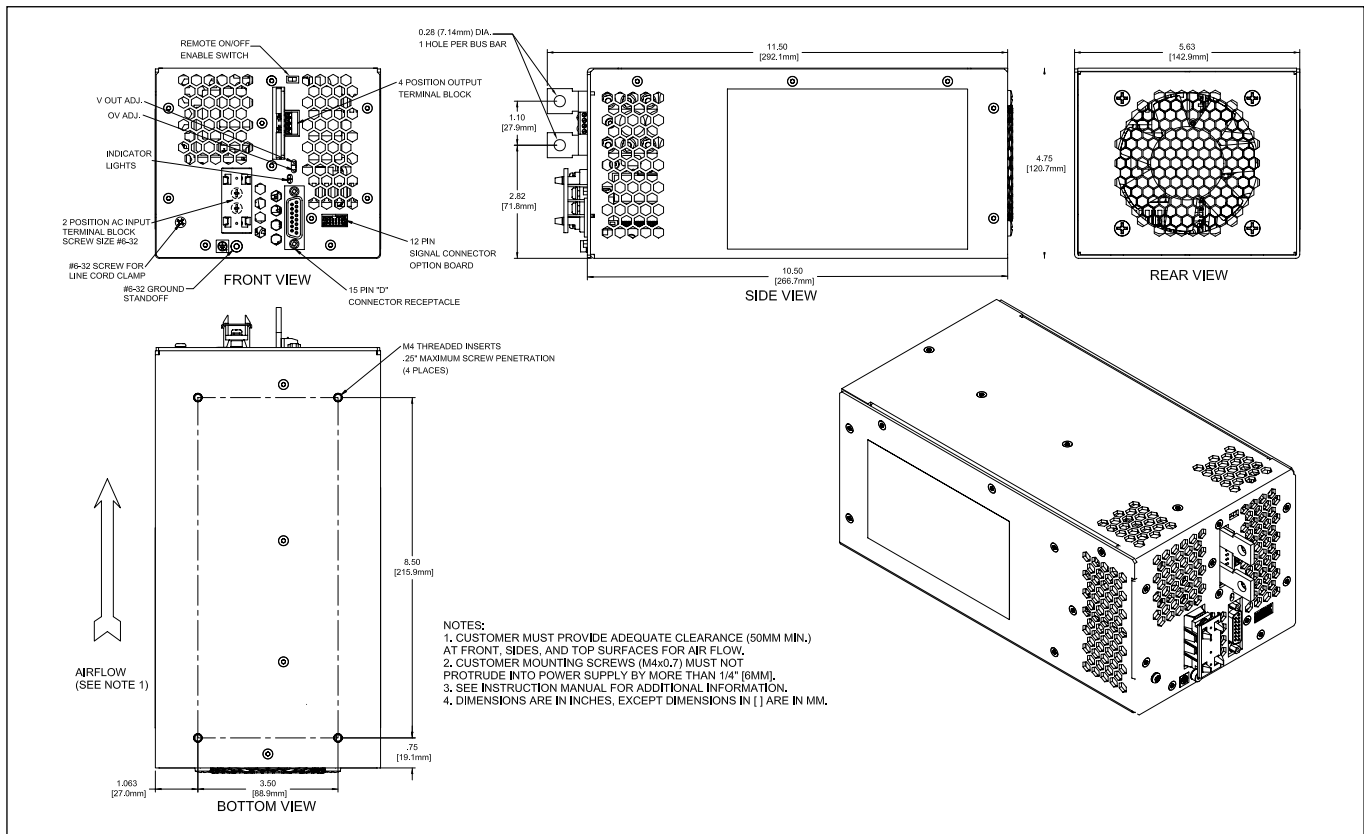

## LZSA 1500 Outline Drawing

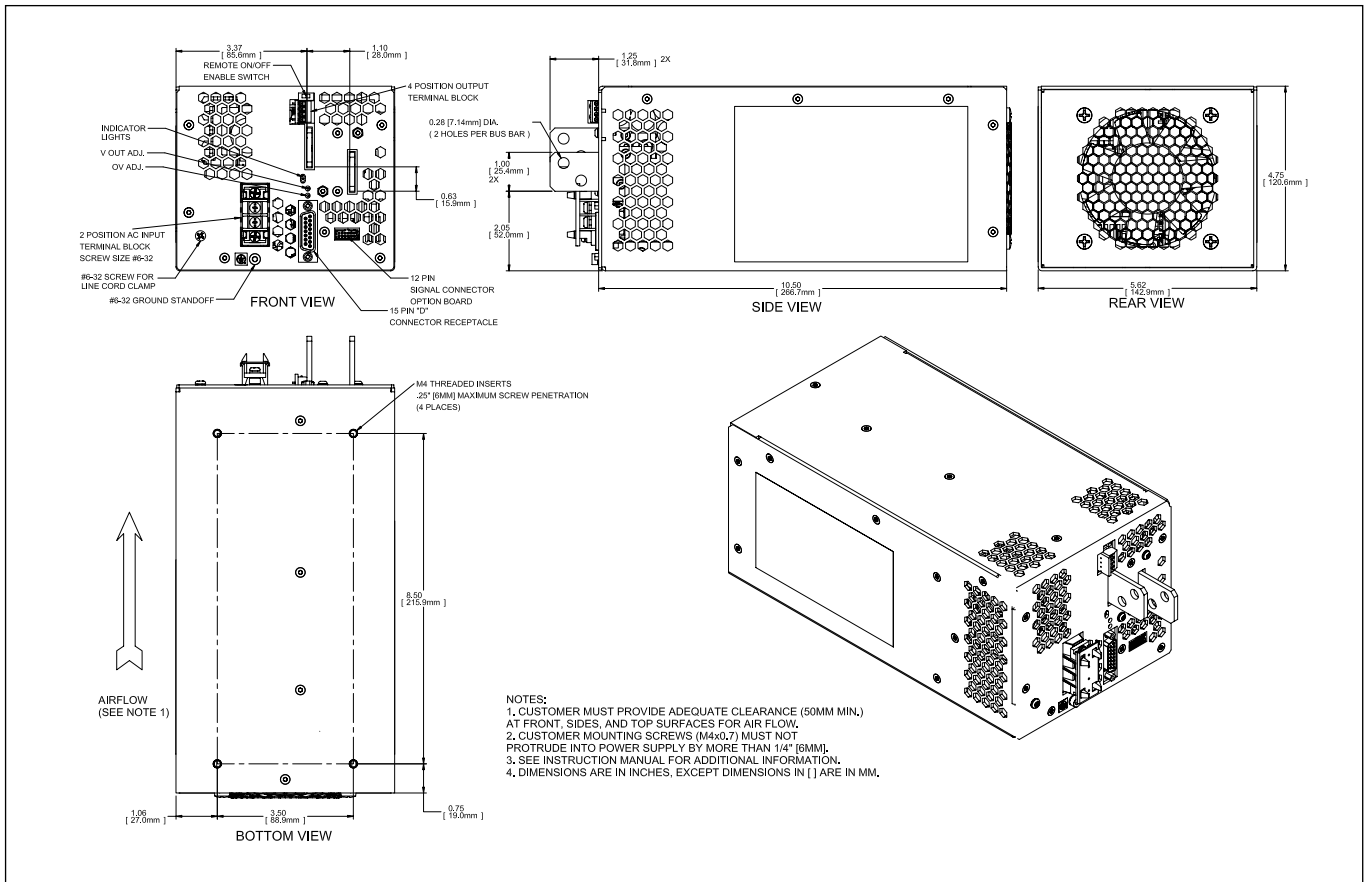



**TDK-Lambda France SAS**

Tel: +33 1 60 12 71 65  
france@fr.tdk-lambda.com  
www.emea.lambda.tdk.com/fr



**Italy Sales Office**

Tel: +39 02 61 29 38 63  
info.italia@it.tdk-lambda.com  
www.emea.lambda.tdk.com/it



**Netherlands**

info@nl.tdk-lambda.com  
www.emea.lambda.tdk.com/nl



**TDK-Lambda Germany GmbH**

Tel: +49 7841 666 0  
info.germany@de.tdk-lambda.com  
www.emea.lambda.tdk.com/de



**Austria Sales Office**

Tel: +43 2256 655 84  
info@at.tdk-lambda.com  
www.emea.lambda.tdk.com/at



**Switzerland Sales Office**

Tel: +41 44 850 53 53  
info@ch.tdk-lambda.com  
www.emea.lambda.tdk.com/ch



**Nordic Sales Office**

Tel: +45 8853 8086  
info@dk.tdk-lambda.com  
www.emea.lambda.tdk.com/dk



**TDK-Lambda UK Ltd.**

Tel: +44 (0) 12 71 85 66 66  
info@uk.tdk-lambda.com  
www.emea.lambda.tdk.com/uk



**TDK-Lambda Ltd.**

Tel: +9 723 902 4333  
info@tdk-lambda.co.il  
www.emea.lambda.tdk.com/il



**C.I.S.**

**Commercial Support:**  
Tel: +7 (495) 665 2627  
**Technical Support:**  
Tel: +7 (812) 658 0463  
info@tdk-lambda.ru  
www.emea.lambda.tdk.com/ru



**TDK-Lambda Americas**

Tel: +1 800-LAMBDA-4 or 1-800-526-2324  
powersolutions@us.tdk-lambda.com  
www.us.lambda.tdk.com



**TDK Electronics do Brasil Ltda**

Tel: +55 11 3289-9599  
sales.br@tdk-electronics.tdk.com  
www.tdk-electronics.tdk.com/en



**TDK-Lambda Corporation**

Tel: +81-3-6778-1113  
www.jp.lambda.tdk.com



**TDK-Lambda (China) Electronics Co. Ltd.**

Tel: +86 21 6485-0777  
powersolutions@cn.tdk-lambda.com  
www.lambda.tdk.com.cn



**TDK-Lambda Singapore Pte Ltd.**

Tel: +65 6251 7211  
tts.mkt@sg.tdk-lambda.com  
www.sg.lambda.tdk.com



**TDK India Private Limited, Power Supply Division**

Tel: +91 80 4039-0660  
mathew.philip@in.tdk-lambda.com  
www.sg.lambda.tdk.com

