

Preliminary Specification of COAXIAL CONNECTOR
 Preliminary SPEC No. : NMM04-PJ0005C
 Part Number : MXJA01JA1000

Written by K. Era
 Checked by T. Kuriyama
 Date 14/Dec./2009

SPECIFICATION

Revised A: 14/Jun./'10 LH, B: 08/Oct./'10 LH, C: 20/Oct./'10 LH

>C

1. MECHANICAL

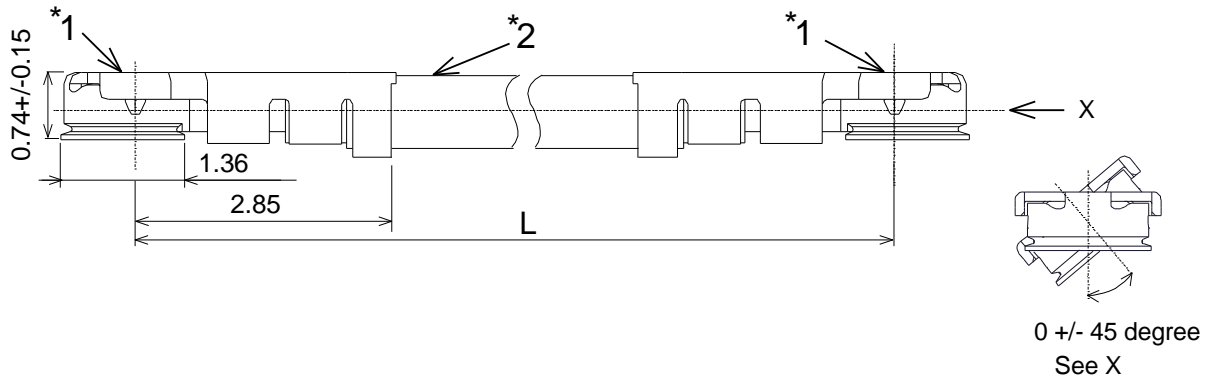

*1: Connector: JSC right angle plug connector
 *2: Cable

Scale: Free
 Tolerances Unless
 Otherwise Specified +/- 0.3
 Unit: mm

>A >B >C

L
100 +/- 3

2. CABLE :

Item	Specification
2.1 Voltage Rating	30V r.m.s. maximum
2.2 Nominal Frequency Range	DC to 12 GHz
2.3 Nominal Impedance	50Ω
2.4 Temperature Rating	-40°C to +85°C
2.5 Used Cable	0.4D Single shield PFA cable

Item	Unit	Construction
Inner conductor	Material	Silver plated copper wire
	No. and Dia.	(No./mm) 7/0.05
	Total Dia.	(mm) 0.15
Insulator	Material	PFA
	Total Dia.	(mm) 0.43
Outer conductor	Material	Silver plated copper wire
	Dia. of wire	(mm) 0.05
Sheath	Material	PFA(White)
	Nominal thickness.	(mm) 0.07
Overall Dia.	(mm)	0.81
Minimum Bending Radius	(mm)	3.3
Nominal Insertion loss	dB/m at 1GHz	2.99
	dB/m at 2GHz	4.32
	dB/m at 3GHz	5.33
	dB/m at 4GHz	6.26
	dB/m at 6GHz	7.83
	dB/m at 9GHz	10.06
	dB/m at 12GHz	12.22



Preliminary Specification of COAXIAL CONNECTOR
Preliminary SPEC No. : NMM04-PJ0005C
Part Number : MXJA01JA1000

Written by K. Era
Checked by T. Kuriyama
Date 14/Dec./2009

SPECIFICATION

Revised A: 14/Jun./'10 LH, B: 08/Oct./'10 LH, C: 20/Oct./'10 LH

3. NOTE

Use tool part# M19201.

The connector to be engaged and disengaged should be inserted or pulled out to the vertical direction.

4.  CAUTION

Limitation of Applications

Please do not use our products for the applications listed below which require specially high reliability for the prevention of defects which may directly or indirectly cause damage to the third party's life, body or property.

- (1) Aircraft equipment
- (2) Aerospace equipment
- (3) Undersea equipment
- (4) Power plant control equipment
- (5) Medical equipment
- (6) Transportation equipment (vehicles, trains, ships, etc.)
- (7) Traffic signal equipment
- (8) Disaster prevention / crime prevention equipment
- (9) Data-processing equipment
- (10) Application of similar complexity and/or reliability requirements to the applications listed in the above.