

1 A 36V Input Low Supply Current LDO

NO.EA-329-220101

OUTLINE

R1518x is a CMOS-based LDO that specifically designed for automotive applications featuring 1 A output current and 36 V input voltage. In addition to a conventional regulator circuit, R1518x consists of a constant slope circuit as a soft-start function, a fold-back protection circuit, a short current limit circuit, and a thermal shutdown circuit. Besides the low supply current by CMOS, the operating temperature is -40°C to 105°C and the maximum input voltage is 36 V, the R1518x is very suitable for power source of car accessories.

R1518x is available in R1518xxxxB/D/E/F with the internally fixed output voltage, and R1518xxxxD/F with the auto-discharge function at standby.

The output voltage of R1518x001C can be set with an external resistor, and the setting range is from 2.5V to Max 20V. R1518xxxxB/C/D internally fixes the soft-start time at 120 μs (Typ). R1518xxxxE/F can adjust the soft-start time with an external capacitor.

R1518x is available in two packages for ultra high wattage: HSOP-6J and TO-252-5-P2.

FEATURES

- Input Voltage Range (Maximum Rating) 3.5 V to 36.0 V (50.0V)
- Operating Temperature rang -40°C to 105°C
- Supply Current Typ. 18 μA
- Standby Current Typ. 0.1 μA
- Dropout Voltage Typ. 0.7 V ($I_{\text{OUT}} = 1 \text{ A}$, $V_{\text{OUT}} = 5.0 \text{ V}$)
- Output Voltage Accuracy $\pm 0.8\%$ ($V_{\text{OUT}} \leq 5.0 \text{ V}$)
- Line Regulation Typ. 0.01%/V
- Packages HSOP-6J, TO-252-5-P2
- Output Voltage Range R1518xxxxB/D/E/F:
2.5V/3.3V/3.4V/5.0V/6.0V/8.5V/9.0V
R1518x001C: Adjustable from 2.5 V to 20.0 V
with external resistor
Feedback Voltage: 2.5 V
- Built-in Short Current Limit Circuit Typ. 150 mA
- Built-in Fold-Back Protection Circuit Min. 1A
- Built-in Thermal Shutdown Circuit Typ. 160°C
- Built-in Soft-start Circuit Typ. 120 μs
R1518xxxxE/F: Adjustable Time Setting with
External Capacitors.
- Ceramic Capacitors can be used R1518xxxxB/D/E/F: 0.1 μF or more
R1518x001C: 1.0 μF or more

APPLICATIONS

- Power source for home appliances such as refrigerators, rice cookers, electric water warmers.
- Power source for notebook PCs, digital TVs, telephones, private LAN systems.
- Power source for office equipment such as copiers, printers, facsimiles, scanners, and projectors

SELECTION GUIDE

The output voltage, version, and package type for this device can be selected at the user's request.

Product Name	Package	Quantity per Reel	Pb Free	Halogen Free
R1518Sxx1*-E2-FE	HSOP-6J	1,000 pcs	Yes	Yes
R1518Jxx1*-T1-FE	TO-252-5-P2	3,000 pcs	Yes	Yes

xx: Specify the set output voltage (V_{SET})

2.5 V (25) / 3.3 V (33) / 3.4 V (34) / 5.0 V (50) / 6.0 V (60) / 8.5 V (85) / 9.0 V (90)

Adjustable output voltage setting type is fixed to (00)

Note: R1518x001C-T1-#E only support

* : Specify the version with desired functions

B: No auto-discharge function

C: No auto-discharge function / Adjustable output voltage setting

D: Auto-discharge function

E: No auto-discharge function / Adjustable soft-start time setting

F: Auto-discharge function / Adjustable soft-start time setting

Auto-Discharge function quickly lowers the output voltage to 0 V by releasing the electrical charge in the external capacitor when the chip enable signal is switched from the active mode to the standby mode.

BLOCK DIAGRAMS

R1518xxxxB

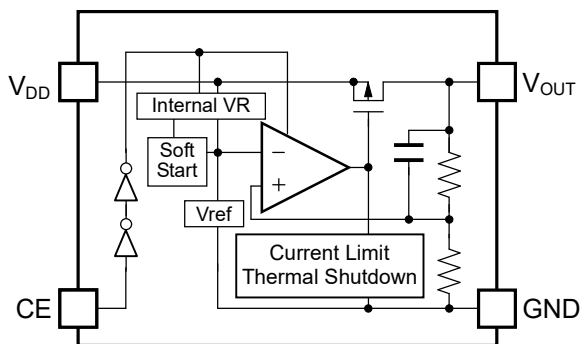

R1518x001C

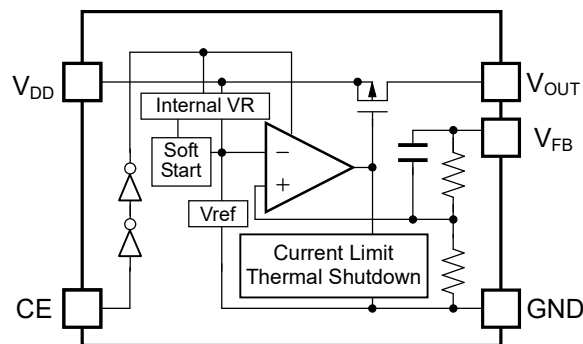

R1518xxxxD

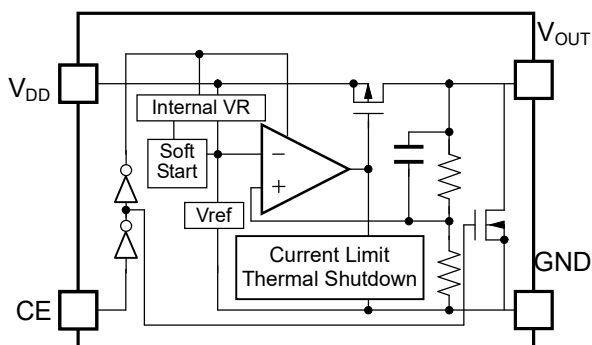

R1518xxxxE

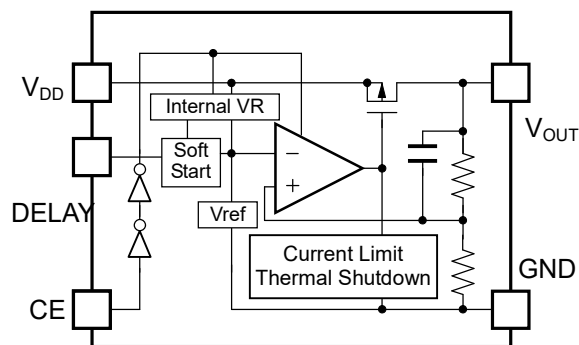

R1518xxxxF

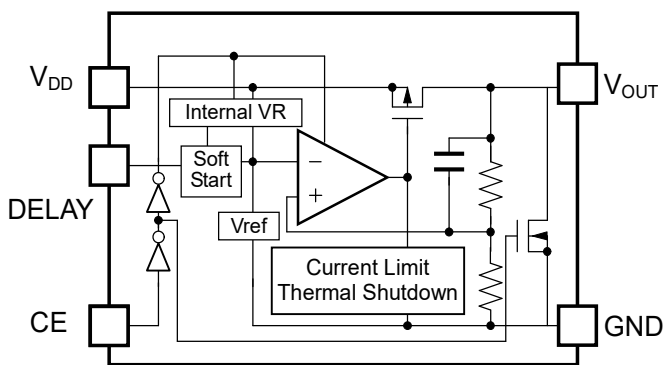

PIN DESCRIPTION

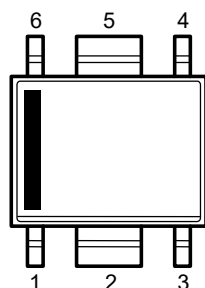

HSOP-6J

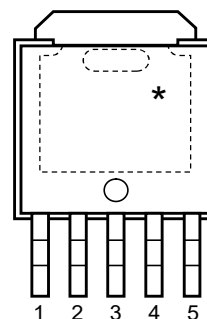

TO-252-5-P2

HSOP-6J

Pin No.	Symbol	Description	
1	VDD	Input Pin	
2	GND	Ground Pin	
3	NC	No Connection	R1518SxxxB/D
	VFB	Feedback Pin	R1518S001C
	DELAY	Adjustable Soft-start Time Pin	R1518SxxxE/F
4	CE	Chip Enable Pin, Active-high	
5	GND	Ground Pin	
6	VOUT	Output Pin	

TO-252-5-P2

Pin No.	Symbol	Description	
1	VDD	Input Pin	
2	NC	No Connection	R1518Jxx1B/D
	VFB	Feedback Pin	R1518J001C
	DELAY	Adjustable Soft-start Time Pin	R1518Jxx1E/F
3	GND	Ground Pin	
4	CE	Chip Enable Pin, Active-high	
5	VOUT	Output Pin	

* The tab on the bottom of the package enhances thermal performance and is electrically connected to GND (substrate level). The tab is recommended to connect to the ground plane on the board. Otherwise it may be left floating.

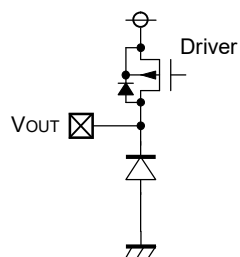
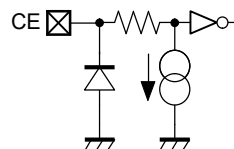
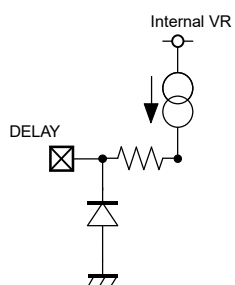
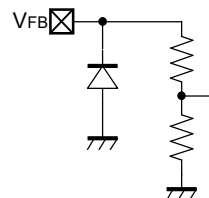
PIN EQUIVALENT CIRCUIT DIAGRAMS**V_{OUT} Pin****CE Pin****DELAY Pin**
(R1518xxxxE/F)**V_{FB} Pin**
(R1518x001C)

ABSOLUTE MAXIMUM RATINGS

Symbol	Item	Rating	Unit	
V_{IN}	Input Voltage	-0.3 to 50	V	
V_{IN}	Peak Input Voltage ⁽¹⁾	60	V	
V_{CE}	Input Voltage (CE Pin)	-0.3 to 50	V	
V_{FB}	Input Voltage (V_{FB} Pin)	-0.3 to 50	V	
V_{OUT}	Output Voltage	-0.3 to $V_{IN} + 0.3 \leq 50$	V	
P_D	Power Dissipation ⁽²⁾ (JEDEC STD.51-7)	HSOP-6J	2700	mW
		TO-252-5-P2	3800	
T_j	Junction Temperature Range	-40 to 125	°C	
T_{stg}	Storage Temperature Range	-55 to 125	°C	

ABSOLUTE MAXIMUM RATINGS

Electronic and mechanical stress momentarily exceeded absolute maximum ratings may cause the permanent damage and may degrade the life time and safety for both device and system using the device in the field. The functional operation at or over these absolute maximum ratings is not assured.

RECOMMENDED OPERATING CONDITIONS

Recommended Operating Conditions

Symbol	Parameter	Rating	Unit
V_{IN}	Input Voltage	3.5 to 36	V
T_a	Operating Temperature Range	-40 to 105	°C

RECOMMENDED OPERATING CONDITIONS

All of electronic equipment should be designed that the mounted semiconductor devices operate within the recommended operating conditions. The semiconductor devices cannot operate normally over the recommended operating conditions, even if they are used over such ratings by momentary electronic noise or surge. And the semiconductor devices may receive serious damage when they continue to operate over the recommended operating conditions.

⁽¹⁾ Duration time = 200 ms

⁽²⁾ Refer to POWER DISSIPATION for detailed information

ELECTRICAL CHARACTERISTICS

$V_{IN} = V_{SET} + 1.0 \text{ V}$, $I_{OUT} = 1 \text{ mA}$, $C_{IN} = C_{OUT} = 0.1 \mu\text{F}$, unless otherwise noted.

The specifications surrounded by are guaranteed by design engineering at $-40^\circ\text{C} \leq T_a \leq 105^\circ\text{C}$.

R1518xxxxB/D

($T_a = 25^\circ\text{C}$)

Symbol	Item	Conditions	Min.	Typ.	Max.	Unit	
V_{OUT}	Output Voltage	$T_a = 25^\circ\text{C}$	$V_{SET} \leq 5.0 \text{ V}$	$\times 0.992$		$\times 1.008$	V
			$V_{SET} > 5.0 \text{ V}$	$\times 0.99$		$\times 1.01$	V
		$-40^\circ\text{C} \leq T_a \leq 105^\circ\text{C}$	$V_{SET} \leq 5.0 \text{ V}$	$\times 0.982$		$\times 1.018$	V
			$V_{SET} > 5.0 \text{ V}$	$\times 0.98$		$\times 1.02$	V
$\frac{\Delta V_{OUT}}{\Delta I_{OUT}}$	Load Regulation	$V_{IN} = V_{SET} + 2.0 \text{ V}$, $1\text{mA} \leq I_{OUT} \leq 250 \text{ mA}$	-15	3	25	mV	
		$V_{IN} = V_{SET} + 2.0 \text{ V}$, $1\text{mA} \leq I_{OUT} \leq 1 \text{ A}$	-60	10	60	mV	
V_{DIF}	Dropout Voltage	$I_{OUT} = 1 \text{ A}$	Refer to the <i>Product-specific Electrical Characteristics</i>				
I_{SS}	Supply Current	$I_{OUT} = 0 \text{ mA}$		18	36	μA	
$I_{standby}$	Standby Current	$V_{CE} = 0 \text{ V}$		0.1	2.0	μA	
$\frac{\Delta V_{OUT}}{\Delta V_{IN}}$	Line Regulation	$V_{SET} + 0.5 \text{ V} \leq V_{IN} \leq 36 \text{ V}$, Under the condition of $V_{IN} \geq 3.5 \text{ V}$		0.01	0.02	%/V	
$\frac{\Delta V_{OUT}}{\Delta T_a}$	Output Voltage Temperature Coefficient	$-40^\circ\text{C} \leq T_a \leq 105^\circ\text{C}$		± 60		ppm/ $^\circ\text{C}$	
I_{LIM}	Output Current Limit	$V_{IN} = V_{SET} + 2.0 \text{ V}$	1			A	
I_{SC}	Short Current Limit	$V_{IN} = 5.0 \text{ V}$, $V_{OUT} = 0 \text{ V}$		150		mA	
I_{PD}	CE Pull-down Current	$V_{CE} = 5.0 \text{ V}$		0.2	0.6	μA	
		$V_{CE} = 36 \text{ V}$		0.5	1.3	μA	
t_{D1}	Soft-start Time 1			120		μs	
V_{CEH}	CE Input Voltage "H"		2.2			V	
V_{CEL}	CE Input Voltage "L"				1.0	V	
T_{TSD}	Thermal Shutdown Temperature	Junction Temperature		160		$^\circ\text{C}$	
T_{TSR}	Thermal Shutdown Released Temperature	Junction Temperature		135		$^\circ\text{C}$	
R_{LOW}	Low Output Nch Tr. ON Resistance (R1518xxxxD)	$V_{IN} = 14.0 \text{ V}$, $V_{CE} = 0 \text{ V}$		3.2		k Ω	

All test items listed under Electrical Characteristics are done under the pulse load condition ($T_j \approx T_a = 25^\circ\text{C}$) except for Output Voltage Temperature Coefficient and Soft-start Time 1.

$V_{IN} = V_{FB} (= 2.5 \text{ V}) + 1.0 \text{ V} = 3.5 \text{ V}$, $I_{OUT} = 1 \text{ mA}$, $C_{IN} = 0.1 \mu\text{F}$, $C_{OUT} = 1.0 \mu\text{F}$ unless otherwise noted.

The specifications surrounded by are guaranteed by design engineering at $-40^\circ\text{C} \leq T_a \leq 105^\circ\text{C}$.

R1518x001C

(Ta = 25°C)

Symbol	Item	Conditions	Min.	Typ.	Max.	Unit
V_{FB}	Feedback Voltage	$T_a = 25^\circ\text{C}$	2.480		2.520	V
		$-40^\circ\text{C} \leq T_a \leq 105^\circ\text{C}$	2.455		2.545	V
$\Delta V_{OUT} / \Delta I_{OUT}$	Load Regulation	$V_{IN} = 4.5 \text{ V}$, $1 \text{ mA} \leq I_{OUT} \leq 250 \text{ mA}$	-10	3	10	mV
		$V_{IN} = 4.5 \text{ V}$, $1 \text{ mA} \leq I_{OUT} \leq 1 \text{ A}$	-25	5	35	mV
V_{DIF}	Dropout Voltage	$I_{OUT} = 1 \text{ A}$		1.0	1.8	V
I_{SS}	Supply Current	$I_{OUT} = 0 \text{ mA}$		18	36	μA
$I_{standby}$	Standby Current	$V_{CE} = 0 \text{ V}$		0.1	2.0	μA
$\Delta V_{OUT} / \Delta V_{IN}$	Line Regulation	$3.5 \text{ V} \leq V_{IN} \leq 36 \text{ V}$		0.01	0.02	%/V
$\Delta V_{OUT} / \Delta T_a$	Output Voltage Temperature Coefficient	$-40^\circ\text{C} \leq T_a \leq 105^\circ\text{C}$		± 60		ppm/ °C
I_{LIM}	Output Current Limit	$V_{IN} = 4.5 \text{ V}$	1			A
I_{SC}	Short Current Limit	$V_{CE} = 5.0 \text{ V}$, $V_{OUT} = V_{FB} = 0 \text{ V}$		150		mA
I_{PD}	CE Pull-down Current	$V_{CE} = 5.0 \text{ V}$		0.2	0.6	μA
		$V_{CE} = 36 \text{ V}$		0.5	1.3	μA
t_{D1}	Soft-start Time 1			120		μs
V_{CEH}	CE Input Voltage "H"		2.2			V
V_{CEL}	CE Input Voltage "L"				1.0	V
T_{TSD}	Thermal Shutdown Temperature	Junction Temperature		160		°C
T_{TSR}	Thermal Shutdown Released Temperature	Junction Temperature		135		°C

$V_{OUT} = V_{FB} = 2.5 \text{ V}$ (excluding short circuit current)

All test items listed under Electrical Characteristics are done under the pulse load condition ($T_j \approx T_a = 25^\circ\text{C}$) except for Output Voltage Temperature coefficient and Soft-start Time 1.

$V_{IN} = V_{SET} + 1.0 \text{ V}$, $I_{OUT} = 1 \text{ mA}$, $C_{IN} = C_{OUT} = 0.1 \mu\text{F}$, unless otherwise noted.

The specifications surrounded by are guaranteed by design engineering at $-40^\circ\text{C} \leq T_a \leq 105^\circ\text{C}$.

R1518xxxxE/F

(Ta = 25°C)

Symbol	Item	Conditions	Min.	Typ.	Max.	Unit		
V_{OUT}	Output Voltage	Ta = 25°C	$V_{SET} \leq 5.0 \text{ V}$	$\times 0.992$		$\times 1.008$	V	
			$V_{SET} > 5.0 \text{ V}$	$\times 0.99$		$\times 1.01$	V	
		$-40^\circ\text{C} \leq T_a \leq 105^\circ\text{C}$	$V_{SET} \leq 5.0 \text{ V}$	$\times 0.982$			$\times 1.018$	V
			$V_{SET} > 5.0 \text{ V}$	$\times 0.98$			$\times 1.02$	V
$\frac{\Delta V_{OUT}}{\Delta I_{OUT}}$	Load Regulation	$V_{IN} = V_{SET} + 2.0 \text{ V}$, $1 \text{ mA} \leq I_{OUT} \leq 250 \text{ mA}$	-15	3	25	mV		
		$V_{IN} = V_{SET} + 2.0 \text{ V}$, $1 \text{ mA} \leq I_{OUT} \leq 1 \text{ A}$	-60	10	60	mV		
V_{DIF}	Dropout Voltage	$I_{OUT} = 1 \text{ A}$	Refer to the <i>Product-specific Electrical Characteristics</i>					
I_{SS}	Supply Current	$I_{OUT} = 0 \text{ mA}$		18	36	μA		
$I_{standby}$	Standby Current	$V_{CE} = 0 \text{ V}$		0.1	2.0	μA		
$\frac{\Delta V_{OUT}}{\Delta V_{IN}}$	Line Regulation	$V_{SET} + 0.5 \text{ V} \leq V_{IN} \leq 36 \text{ V}$, Under the condition of $V_{IN} \geq 3.5 \text{ V}$		0.01	0.02	%/V		
$\frac{\Delta V_{OUT}}{\Delta T_a}$	Output Voltage Temperature Coefficient	$-40^\circ\text{C} \leq T_a \leq 105^\circ\text{C}$		± 60		ppm/ °C		
I_{LIM}	Output Current Limit	$V_{IN} = V_{SET} + 2.0 \text{ V}$	1			A		
I_{SC}	Short Current Limit	$V_{IN} = 5.0 \text{ V}$, $V_{OUT} = 0 \text{ V}$		150		mA		
I_{PD}	CE Pull-down Current	$V_{CE} = 5.0 \text{ V}$		0.2	0.6	μA		
		$V_{CE} = 36 \text{ V}$		0.5	1.3	μA		
I_{DELAY}	DELAY Current	DELAY = GND	1.5	2.5	3.5	μA		
t_{D1}	Soft-start Time 1	DELAY = OPEN		26		μs		
t_{D2}	Soft-start Time 2	DELAY = 0.001 μF	210	290	415	μs		
V_{CEH}	CE Input Voltage "H"		2.2			V		
V_{CEL}	CE Input Voltage "L"				1.0	V		
T_{TSD}	Thermal Shutdown Temperature	Junction Temperature		160		°C		
T_{TSR}	Thermal Shutdown Released Temperature	Junction Temperature		135		°C		
R_{LOW}	Low Output Nch Tr. ON Resistance (R1518xxx1F)	$V_{IN} = 14.0 \text{ V}$, $V_{CE} = 0 \text{ V}$		3.2		k Ω		

All test items listed under Electrical Characteristics are done under the pulse load condition ($T_j \approx T_a = 25^\circ\text{C}$) except for Output Voltage Temperature Coefficient, Soft-start Time 1, and Soft-start Time 2.

The specifications surrounded by are guaranteed by design engineering at $-40^{\circ}\text{C} \leq T_a \leq 105^{\circ}\text{C}$.

R1518xxxxB/D/E/F Product-specific Electrical Characteristics**(Ta = 25°C)**

Product Name	V _{OUT} [V] (Ta = 25°C)			V _{OUT} [V] (-40°C ≤ Ta ≤ 105°C)			V _{DIF} [V]	
	Min.	Typ.	Max.	Min.	Typ.	Max.	Typ.	Max.
R1518x251x	2.480	2.500	2.520	2.455	2.500	2.545	1.00	1.80
R1518x331x	3.274	3.300	3.326	3.241	3.300	3.359	0.90	1.60
R1518x341x	3.373	3.400	3.427	3.339	3.400	3.461		
R1518x501x	4.960	5.000	5.040	4.910	5.000	5.090	0.70	1.30
R1518x601x	5.940	6.000	6.060	5.880	6.000	6.120		
R1518x851x	8.415	8.500	8.585	8.330	8.500	8.670	0.65	1.10
R1518x901x	8.910	9.000	9.090	8.820	9.000	9.180	0.65	1.10

OPERATION DESCRIPTION

Thermal Shutdown Function

Thermal shutdown function is included in this device. If the junction temperature is more than or equal to 160°C (Typ.), the operation of the regulator would stop. After that, when the junction temperature is less than or equal to 135°C (Typ.), the operation of the regulator would restart. Unless the cause of rising temperature is removed, the regulator repeats on and off, and output waveform would be like consecutive pulses.

Adjustable Output Voltage Setting (R1518x001C)

The output voltage of R1518x001C can be adjusted by using the external divider resistors (R1, R2). By using the following equation, the output voltage (V_{OUT}) can be determined. The voltage which is fixed inside the IC is described as V_{FB} .

$$V_{OUT} = V_{FB} \times ((R1 + R2) / R2)$$

Recommended Range: $2.5 \text{ V} \leq V_{OUT} \leq 20.0 \text{ V}$

$$V_{FB} = 2.5 \text{ V}$$

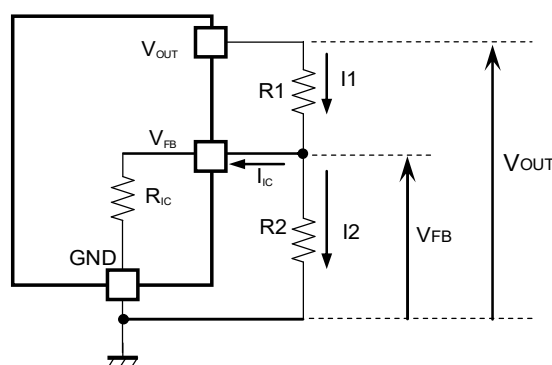

Output Voltage Adjustment Using External Divider Resistors (R1, R2)

R_{IC} of the R1518x001C is approximately Typ. 1.35 M Ω ($T_a=25^\circ\text{C}$, guaranteed by design engineering). For better accuracy, setting $R1 \ll R_{IC}$ reduces errors. The resistance value for R2 should be set to 10 k Ω or lower. It is easily affected by noises when setting the value of R1 and R2 larger, which makes the impedance of V_{FB} pin larger.

R_{IC} could be affected by the temperature, therefore evaluate the circuit taking the actual conditions of use into account when deciding the resistance values for R1 and R2.

Soft-start Function

R1518x is equipped with a constant slope circuit, which achieves a soft-start function. This circuit allows the output voltage to start up gradually when the CE is turned on. The constant slope circuit minimizes the inrush current at the start-up and also prevents the overshoot of the output voltage. For R1518xxxxB/C/D, the capacitor to create the start-up slope is built in this device that does not require any external components. The start-up time and the start-up slope angle are fixed inside the device. As for R1518xxxxE/F, the soft-start time is adjustable by inserting the external capacitor to DELAY pin. By using the following equation, the relation between the soft-start time t_D [s] and DELAY pin capacitor C_D [F] is determined.

$$t_D = ((C_D + 90 \times 10^{-12}) / I_{\text{DELAY}}) \times 0.73$$

When the capacitor C_D of R1518xxxxE/F is not used, use the DELAY pin as OPEN. At that time, $C_D = 0$ in the above equation, therefore the start-up time is about 26 μs . However, be sure to consider approximately 50 μs of CE delay time.

The capacity (C_D) of the DELAY pin is discharged when V_{IN} is input and $\text{CE} = \text{L}$. If the C_D is restarted without being discharged, the soft start time may be shorter than the set time.

Conventional Inrush Current Limit Circuit

(Diagrammatic sketch)

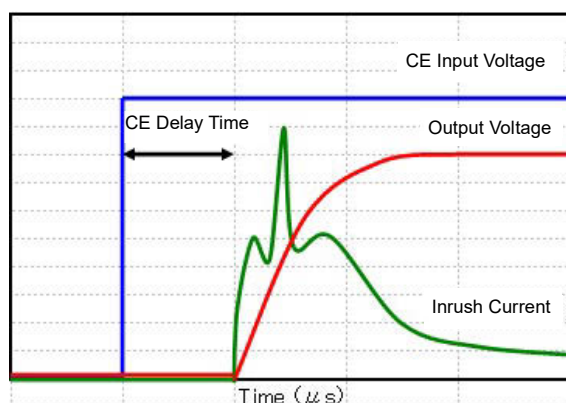

Constant Slope Circuit

(Diagrammatic sketch)

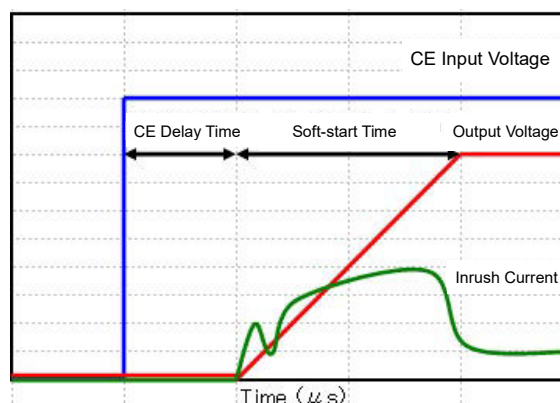

APPLICATION INFORMATION

TYPICAL APPLICATION

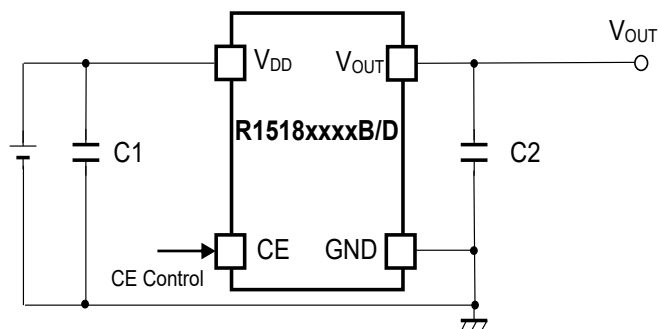

R1518xxxxB/D Typical Application

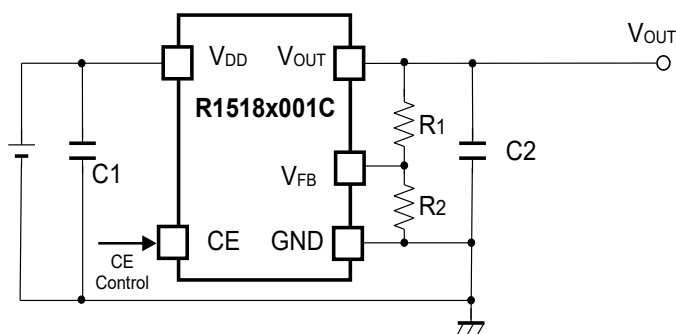

R1518x001C Typical Application

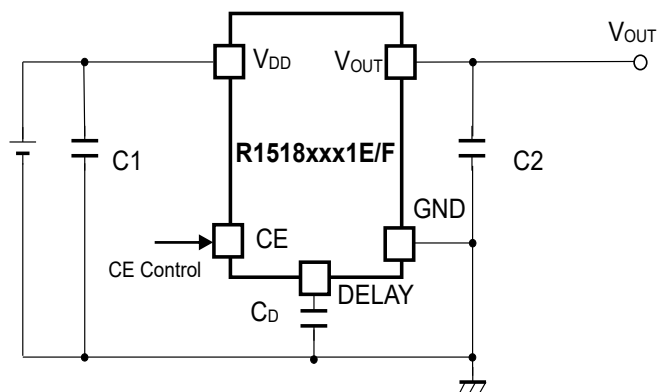

R1518xxx1E/F Typical Application

External Components :

Symbol	Description
R1518xxxxB/D/E/F	
C1 (C _{IN})	0.1μF (Ceramic)
C2 (C _{OUT})	0.1μF (Ceramic)
R1518x001C	
C1 (C _{IN})	0.1μF (Ceramic)
C2 (C _{OUT})	1.0μF (Ceramic)

ESR vs. Output Current

It is recommended that a ceramic type capacitor be used for this device. However, other types of capacitors having lower ESR can also be used. The relation between the output current (I_{OUT}) and the ESR of output capacitor is shown below.

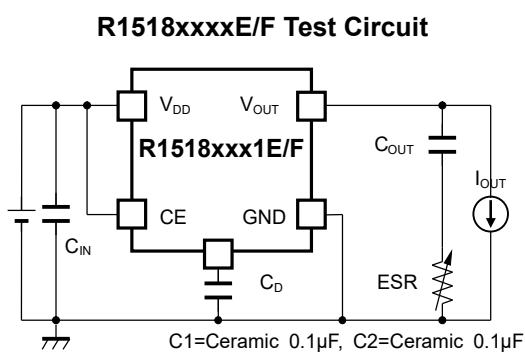
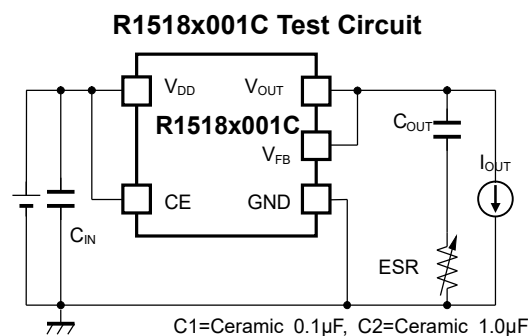
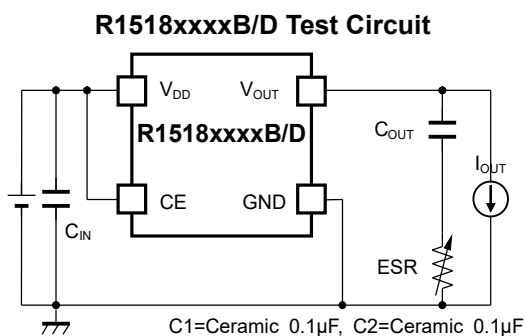

Measurement conditions

- Frequency Band: 10 Hz to 2 MHz
- Measurement Temperature: -40°C to 105°C
- Hatched area: Noise level is 40 μ V (average) or below
- Capacitor: C1 = Ceramic 0.1 μ F, C2 = 0.1 μ F

R1518x25xx Output Current I_{OUT} vs. ESR

V_{in} =2.5V to 36V

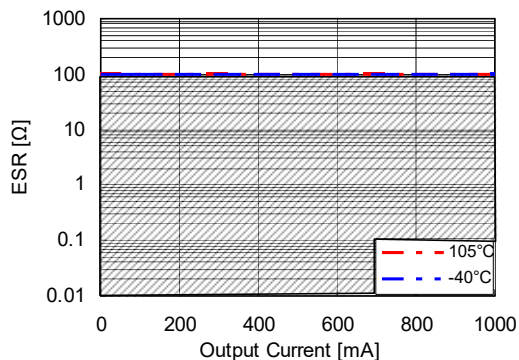

R1518x85xx Output Current I_{OUT} vs. ESR

V_{in} =8.5V to 36V

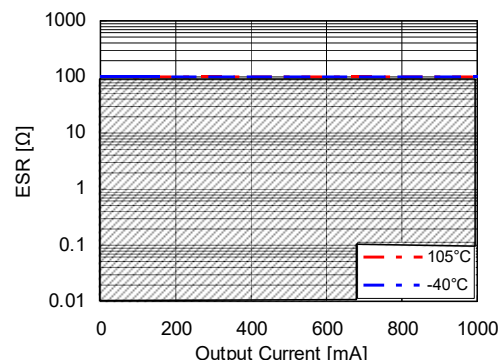

TECHNICAL NOTES

Phase Compensation

In LDO regulators, phase compensation is provided to secure stable operation even when the load current is varied. For this purpose, use 0.1 μF or more (R1518xxxxB/D/E/F), 1.0 μF or more (R1518x001C) of the capacitor C2. When using a tantalum type capacitor and the ESR (Equivalent Series Resistance) value is large, the output might be unstable. Evaluate the circuit including consideration of frequency characteristics. For the externally adjustable output voltage type (R1518x001C), use 10 $\text{k}\Omega$ or lower resistance R2.

PCB Layout

Ensure the V_{DD} and GND lines are sufficiently robust. If their impedance is too high, noise pickup or unstable operation may result. Connect 0.1 μF or more of the capacitor C1 between the V_{DD} and GND, and as close as possible to the pins.

In addition, connect the capacitor C2 between V_{OUT} and GND, and as close as possible to the pins.

TYPICAL CHARACTERISTICS

Note: Typical Characteristics are intended to be used as reference data; they are not guaranteed.

1) Output Voltage vs. Output Current (Ta = 25°C)

R1518x25xx, R1518x001C

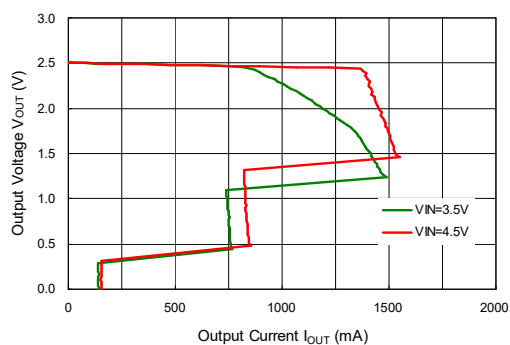

R1518x33xx

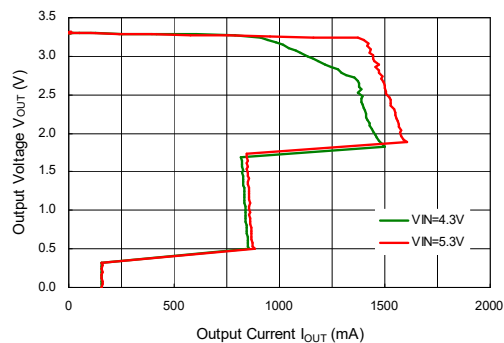

R1518x50xx

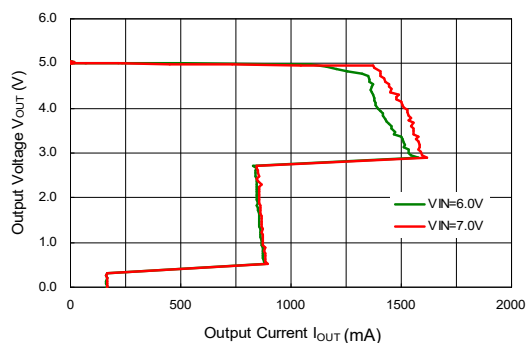

R1518x85xx

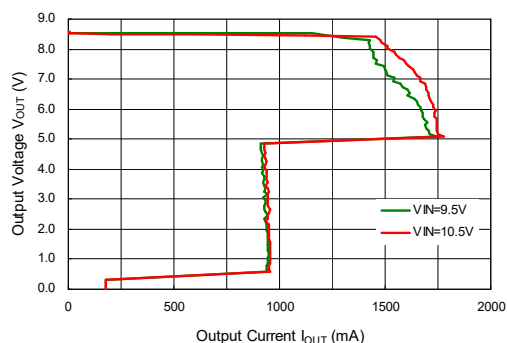

2) Output Voltage vs. Input Voltage (Ta = 25°C)

R1518x25xx

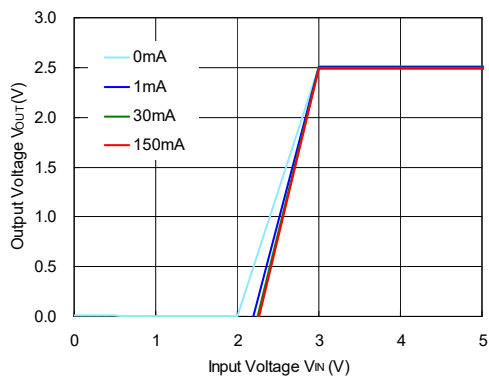

R1518x33xx

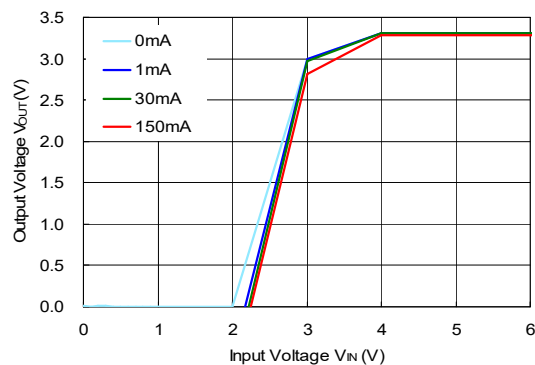

R1518x50xx

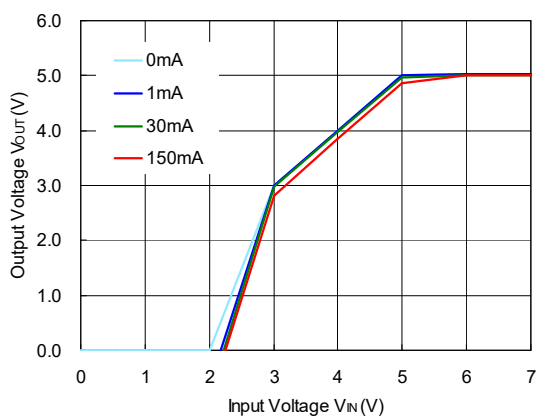

R1518x85xx

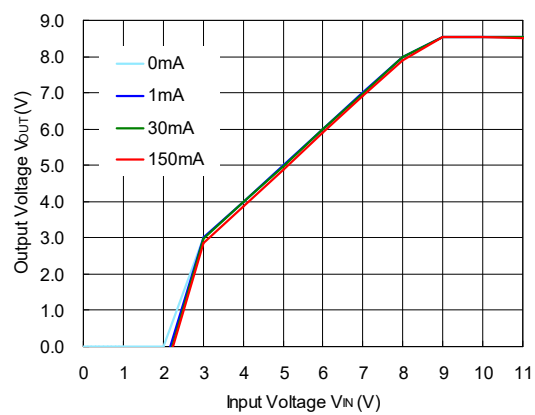

3) Supply Current vs. Input Voltage

R1518x25xx, R1518x001C

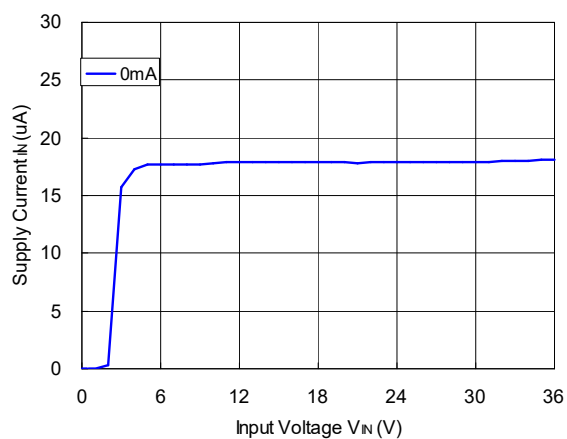

R1518x33xx

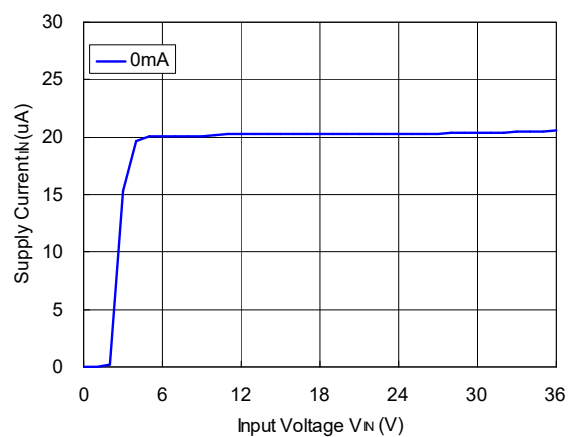

R1518x50xx

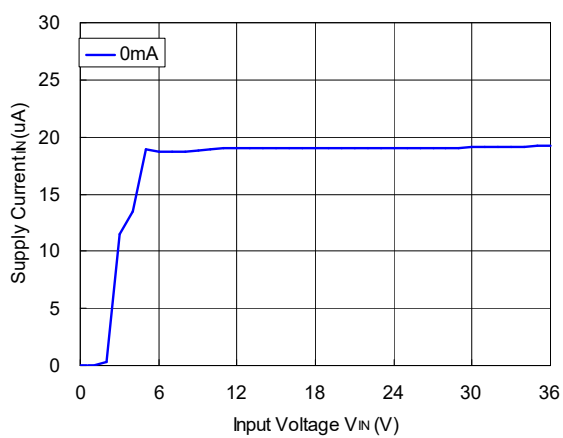

R1518x85xx

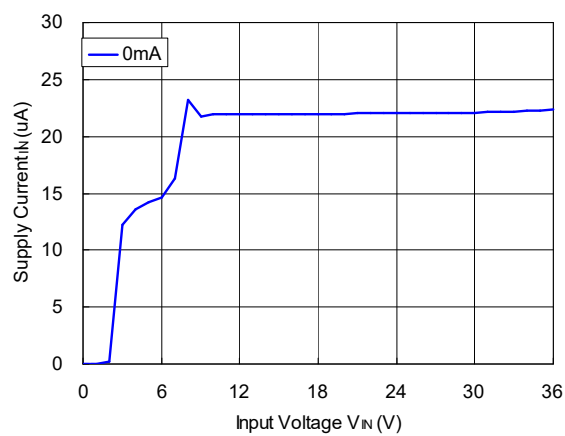

4) Output Voltage vs. Operating Temperature

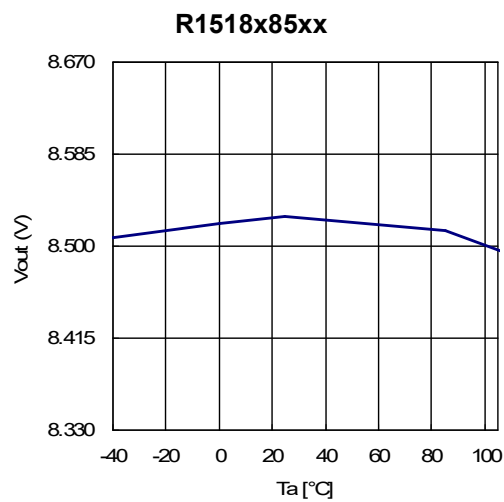
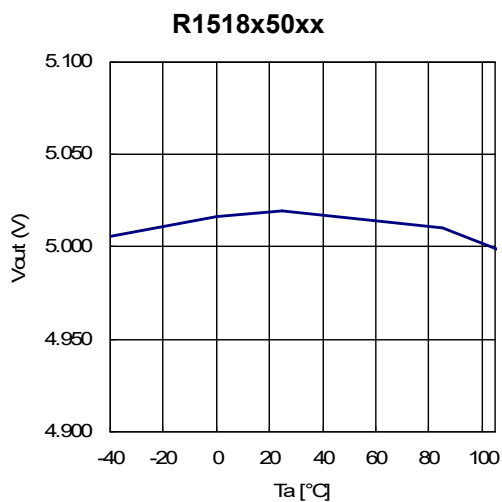
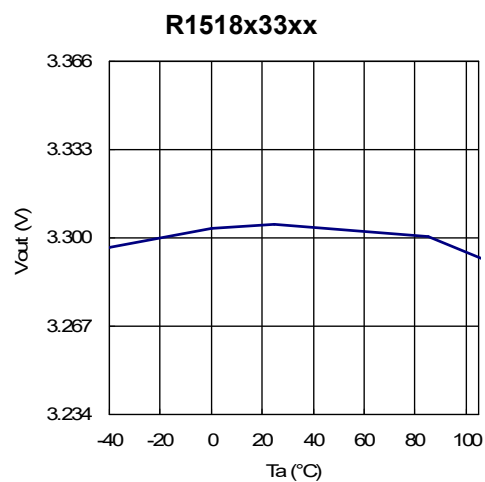
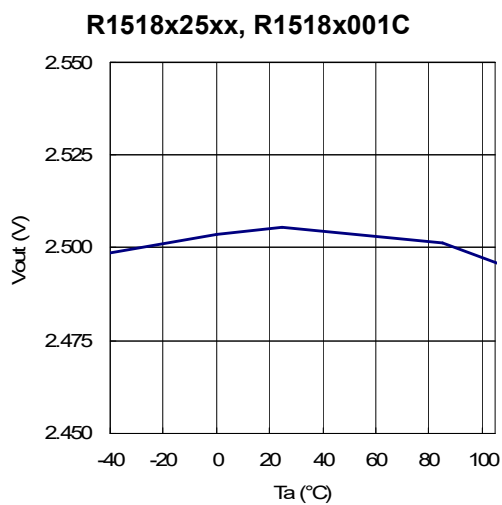

5) Dropout Voltage vs. Output Current

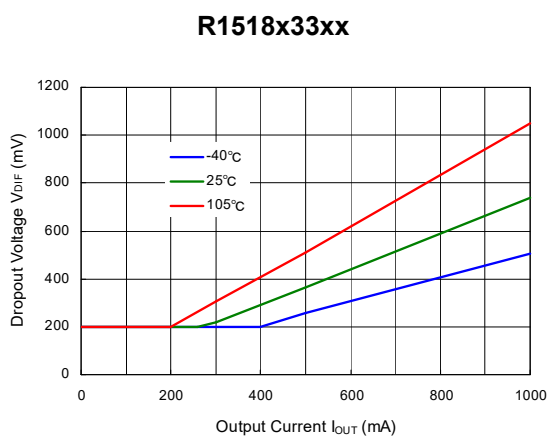
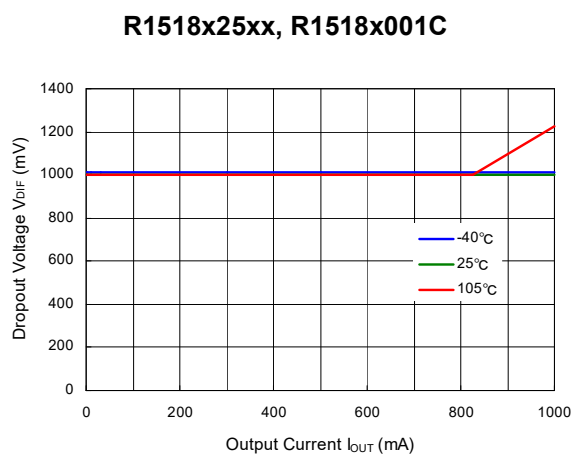

R1518x50xx

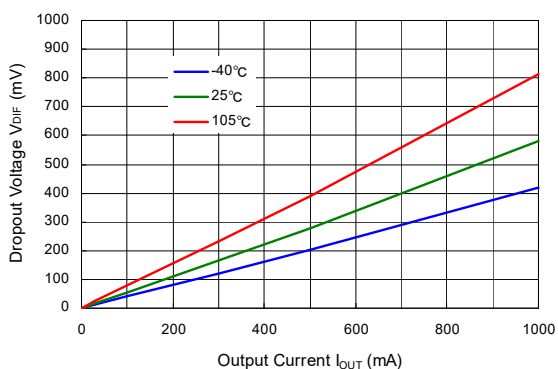

R1518x85xx

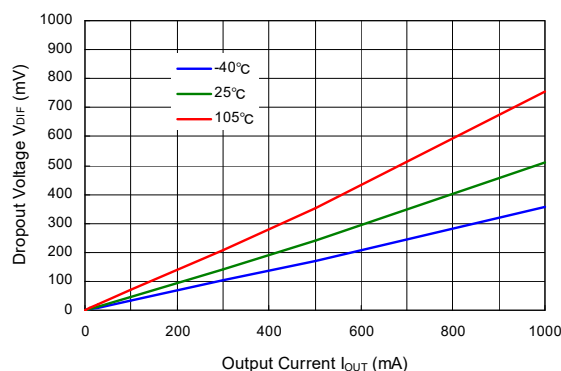

6) Ripple Rejection vs. Input Voltage ($T_a = 25^\circ\text{C}$, Ripple = 0.5 Vpp)

R1518x25xx, R1518x001C ($I_{OUT} = 1\text{ mA}$)

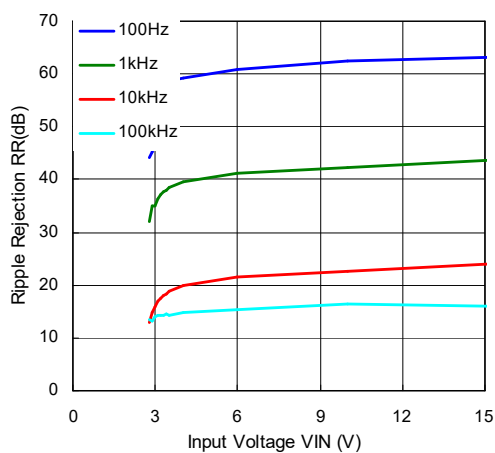

R1518x25xx, R1518x001C ($I_{OUT} = 300\text{ mA}$)

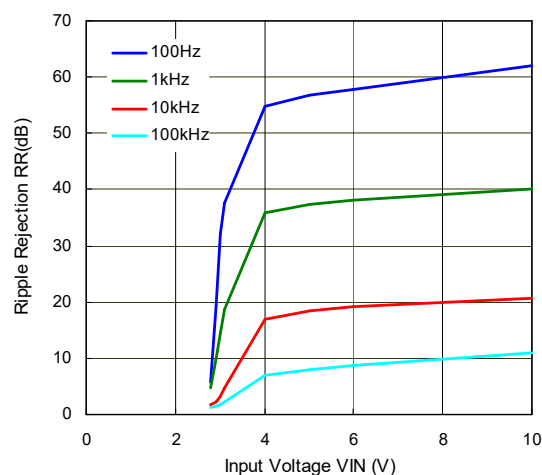

R1518x33xx ($I_{OUT} = 1\text{ mA}$)

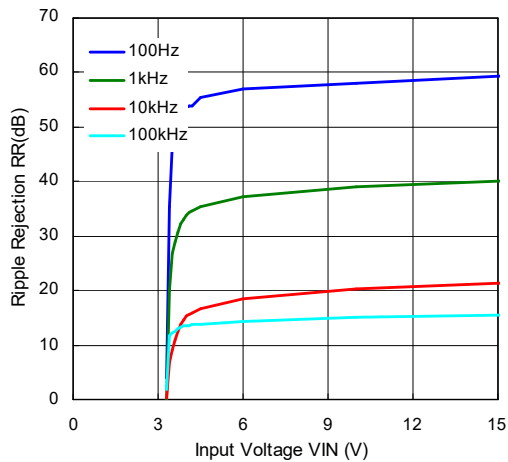

R1518x33xx ($I_{OUT} = 300\text{ mA}$)

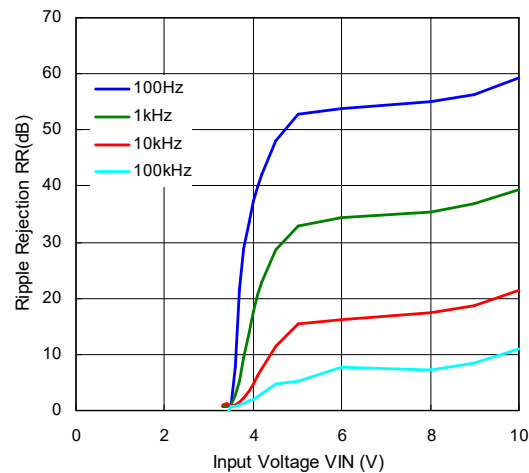

R1518x50xx (I_{OUT} = 1 mA)

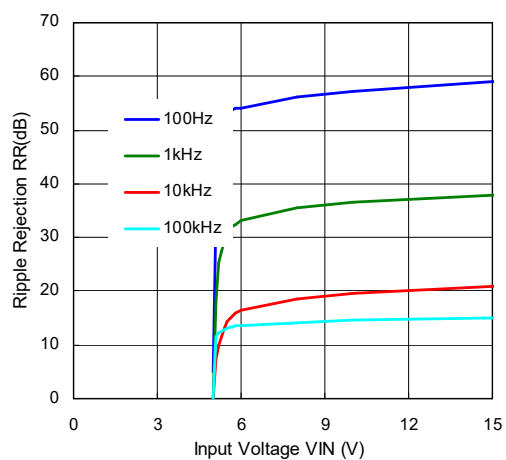

R1518x50xx (I_{OUT} = 300 mA)

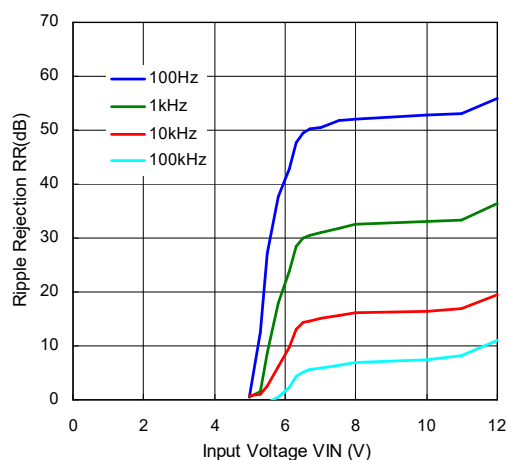

R1518x85xx (I_{OUT} = 1 mA)

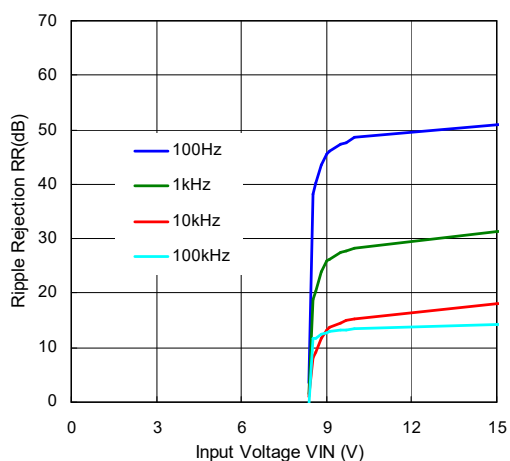

R1518x85xx (I_{OUT} = 300 mA)

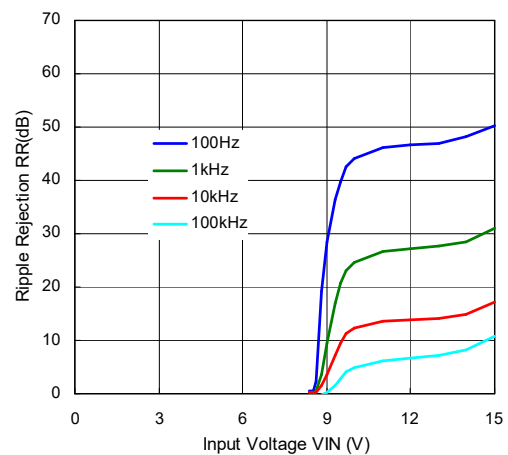

7) Ripple Rejection vs. Frequency (Ta = 25°C, Ripple = 0.5 Vpp)

R1518x25xx, R1518x001C

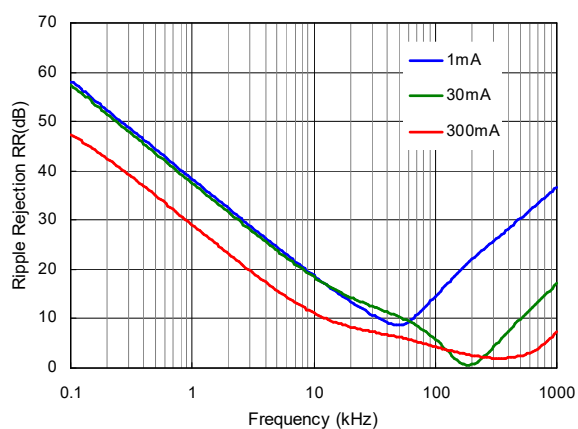

R1518x33xx

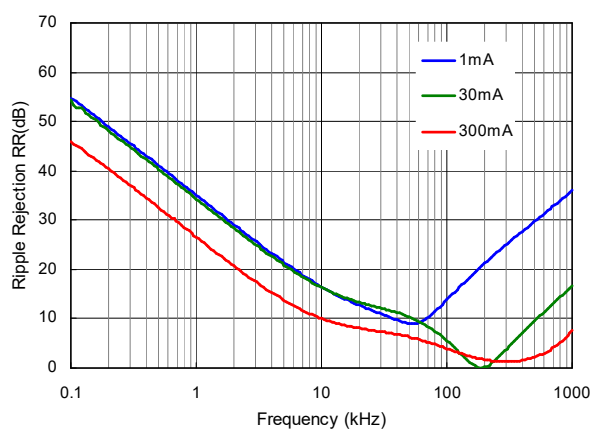

R1518x50xx

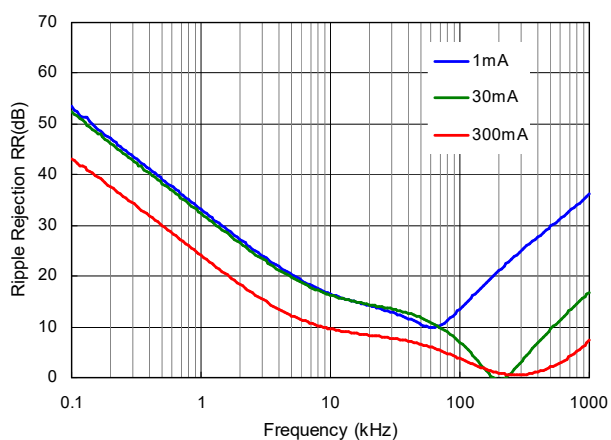

R1518x85xx

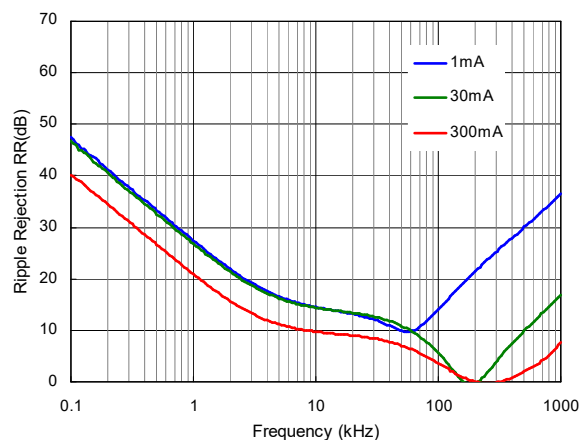

8) Input Transient Response ($T_a = 25^\circ\text{C}$, $I_{OUT} = 1\text{ mA}$, $t_r = t_f = 5\ \mu\text{s}$)

R1518x25xx, R1518x001C ($C_2 = 0.1\ \mu\text{F}$)

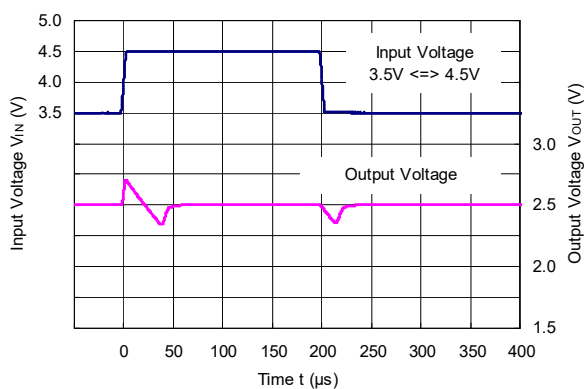

R1518x25xx, R1518x001C ($C_2 = 10\ \mu\text{F}$)

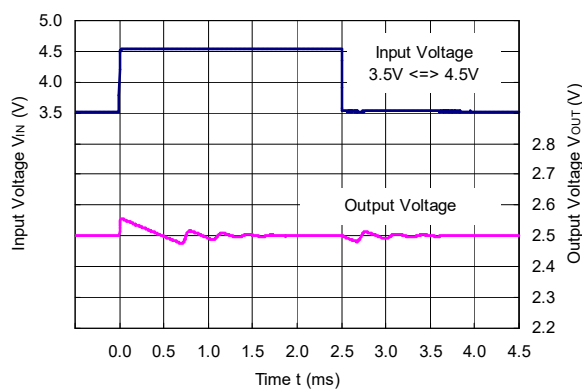

R1518x33xx ($C_2 = 0.1\ \mu\text{F}$)

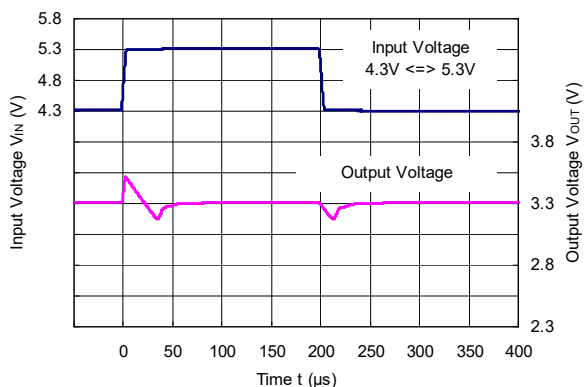

R1518x33xx ($C_2 = 10\ \mu\text{F}$)

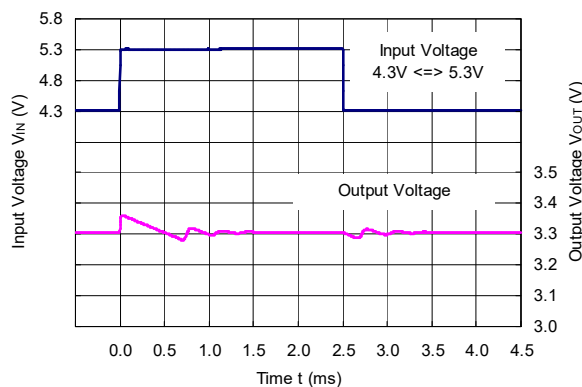

R1518x50xx (C2 = 0.1 μ F)

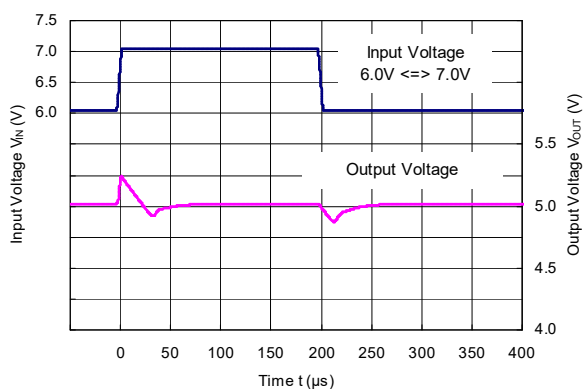

R1518x50xx (C2 = 10 μ F)

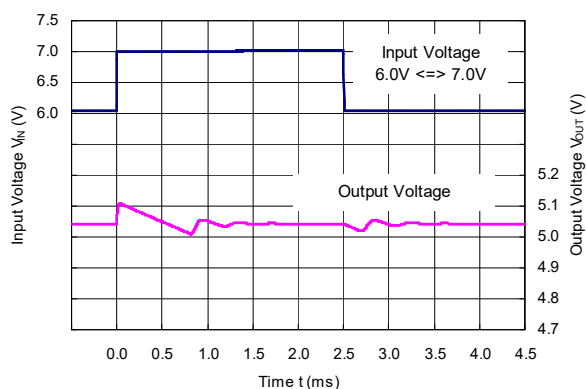

R1518x85xx (C2 = 0.1 μ F)

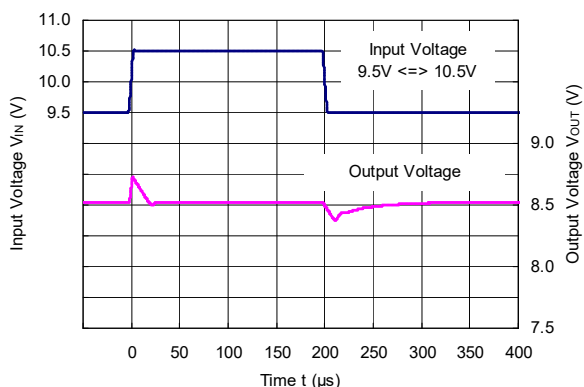

R1518x85xx (C2 = 10 μ F)

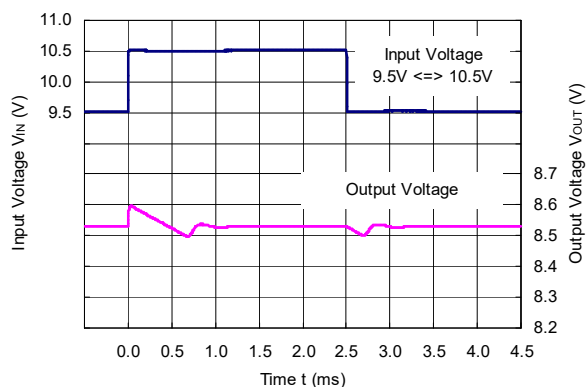

9) Load Transient Response ($T_a = 25^\circ\text{C}$, $V_{IN} = V_{OUT} + 1.0\text{ V}$, $t_r = t_f = 0.5\ \mu\text{s}$)

R1518x25xx, R1518x001C (C2 = 0.1 μ F)

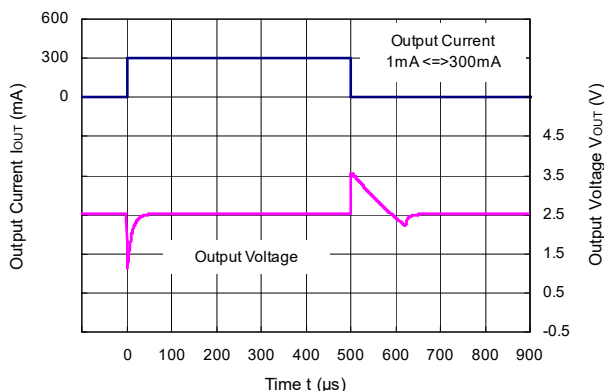

R1518x25xx, R1518x001C (C2 = 10 μ F)

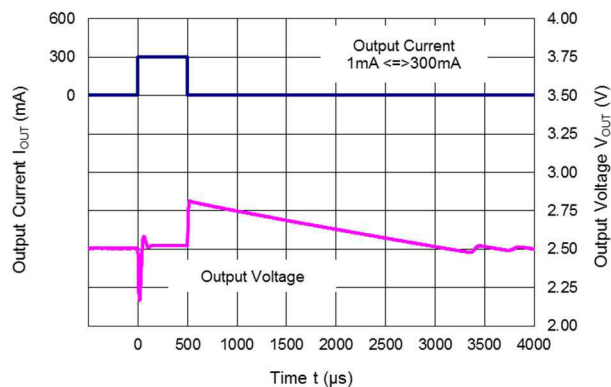

R1518x33xx (C2 = 0.1 μF)

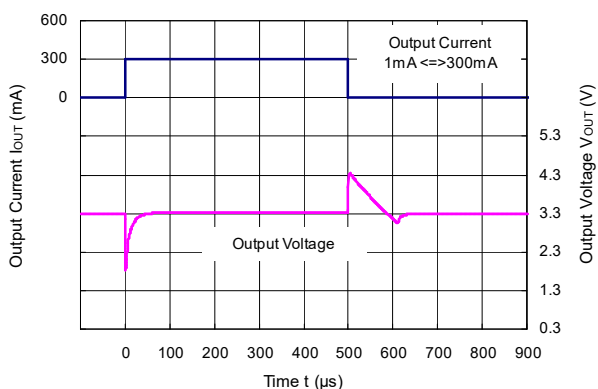

R1518x33xx (C2 = 10 μF)

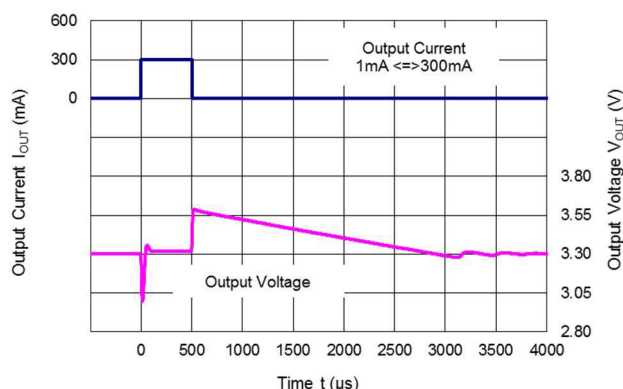

R1518x50xx (C2 = 0.1 μF)

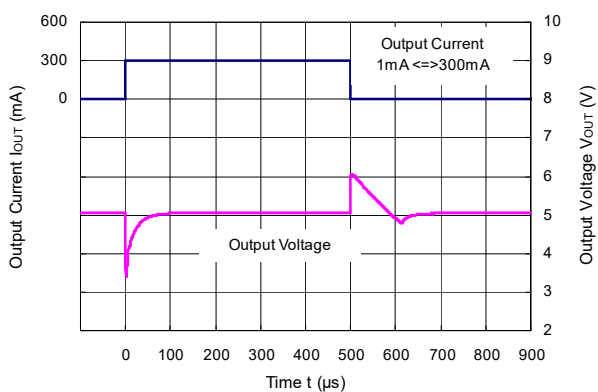

R1518x50xx (C2 = 10 μF)

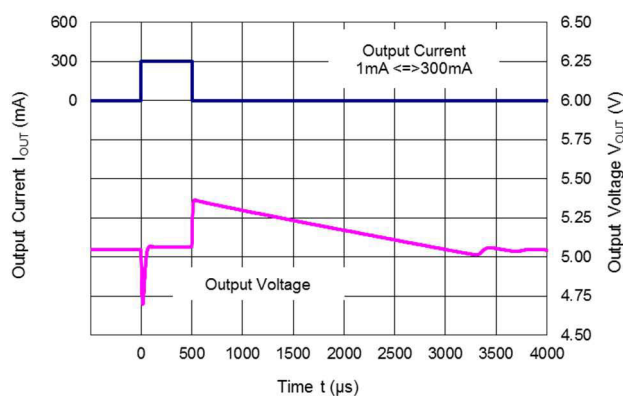

R1518x85xx (C2 = 0.1 μF)

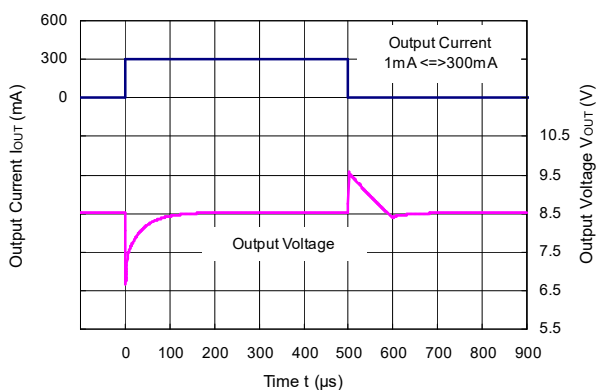

R1518x85xx (C2 = 10 μF)

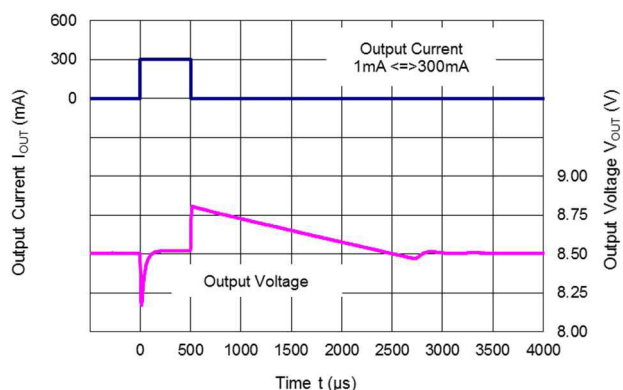

10) CE Transient Response (Ta = 25°C)

R1518x25xB/D, R1518x001C (C2 = 0.1 μF)

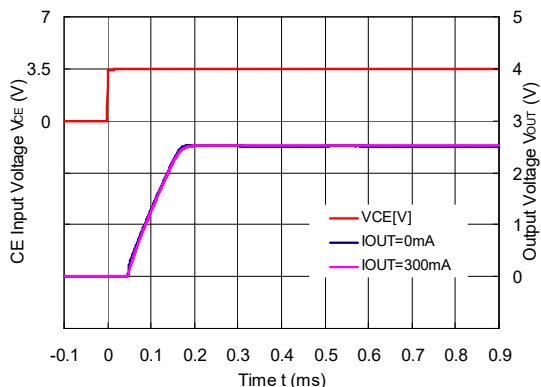

R1518x25xD (C2 = 0.1 μF)

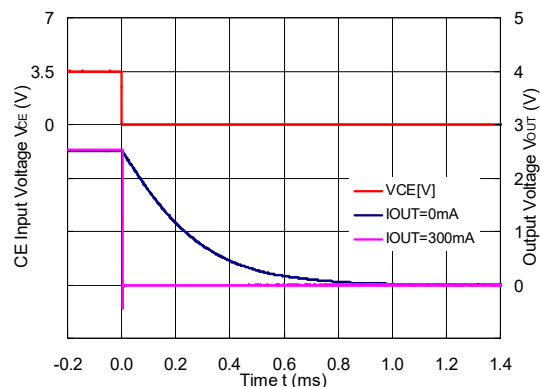

R1518x33xB/D (C2 = 0.1 μF)

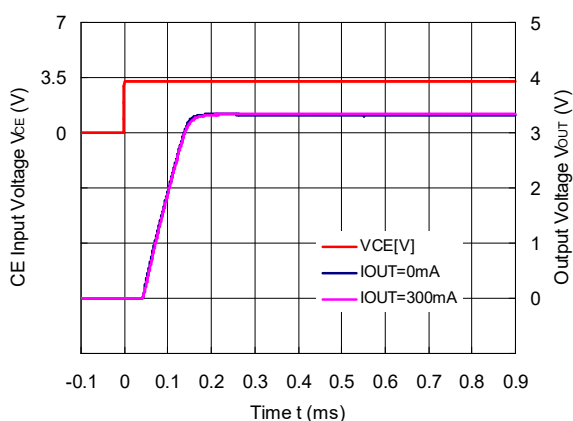

R1518x33xD (C2 = 0.1 μF)

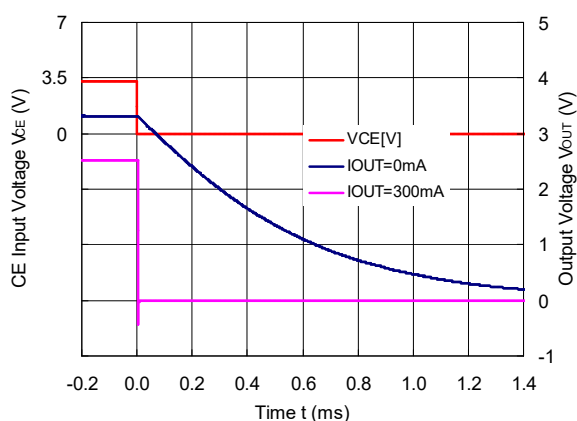

R1518x50xB/D (C2 = 0.1 μF)

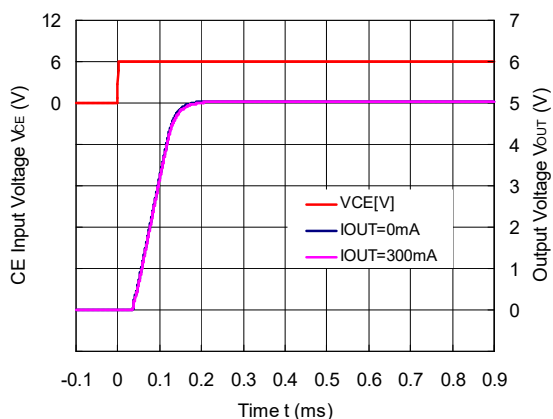

R1518x50xD (C2 = 0.1 μF)

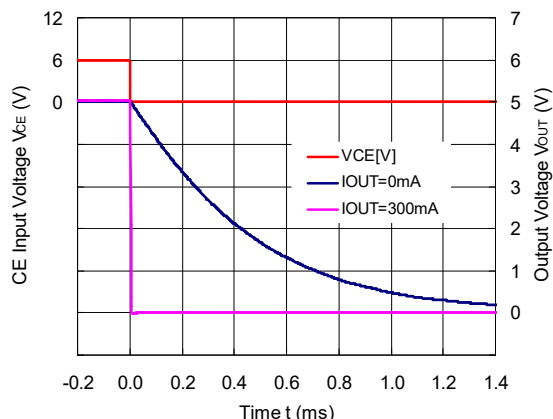

R1518x85xB/D (C2 = 0.1 μ F)

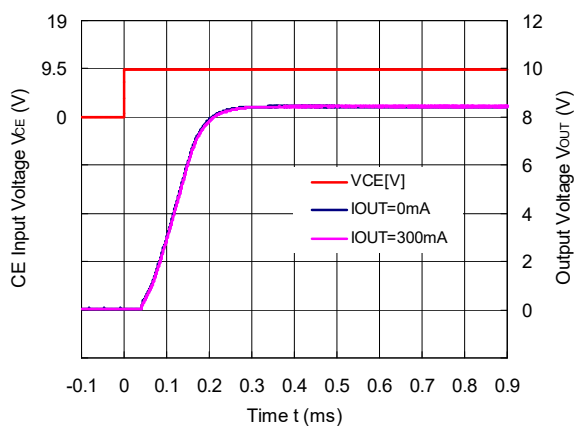

R1518x85xD (C2 = 0.1 μ F)

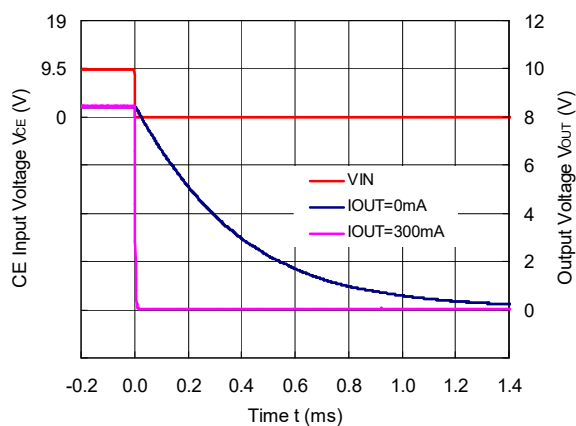

R1518x25xE/F (C2 = 0.1 μ F, C_D = 1 nF)

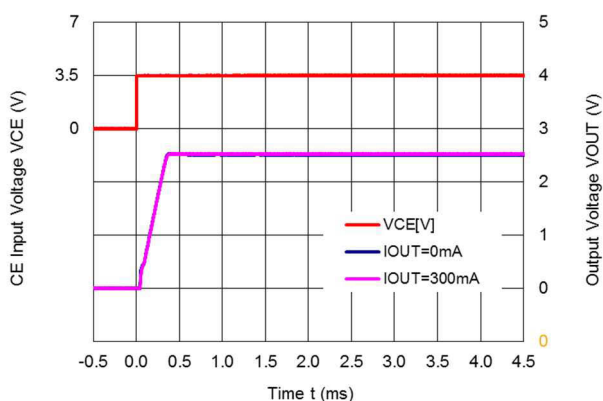

R1518x25xF (C2 = 0.1 μ F, C_D = 1 nF)

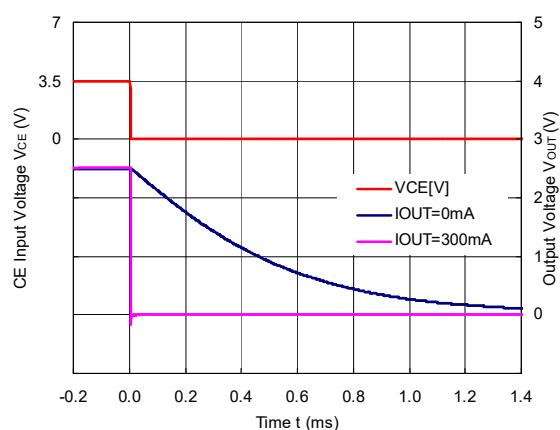

R1518x33xE/F (C2 = 0.1 μ F, C_D = 1 nF)

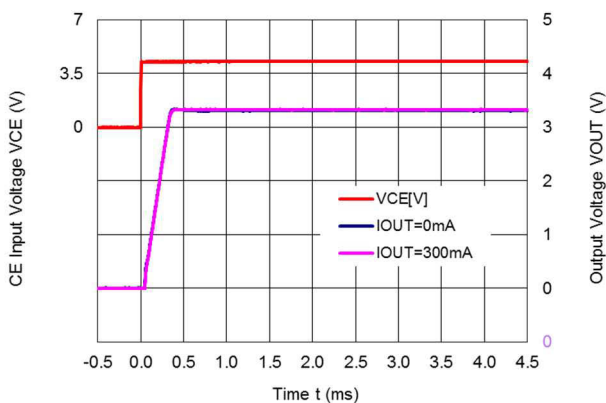

R1518x33xF (C2 = 0.1 μ F, C_D = 1 nF)

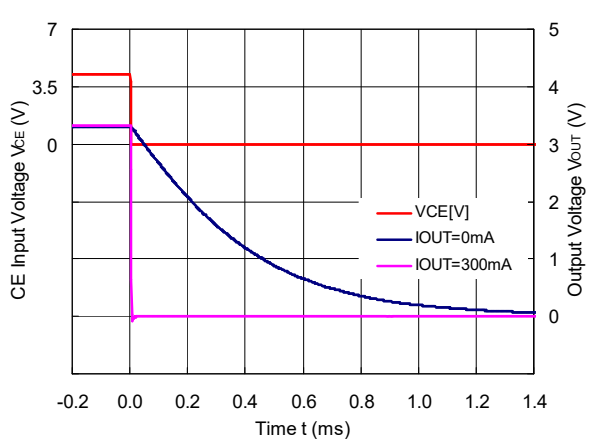

R1518x50xE/F (C2 = 0.1 μF, CD = 1 nF)

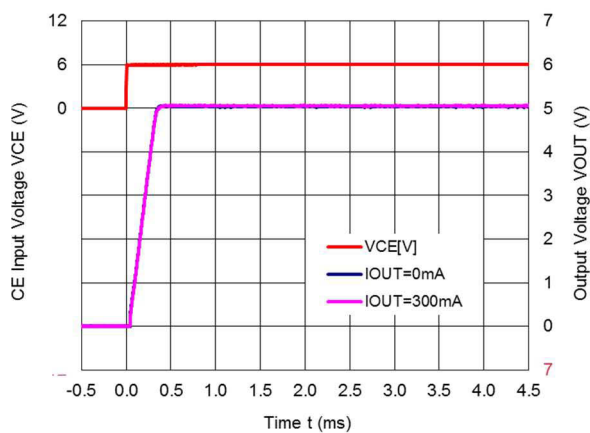

R1518x50xF (C2 = 0.1 μF, CD = 1 nF)

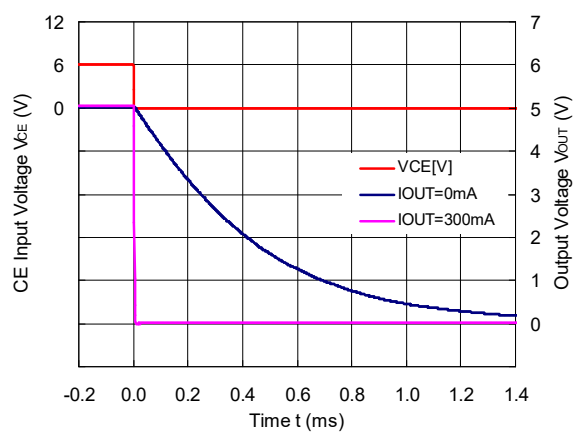

R1518x851E/F (C2 = 0.1 μF, CD = 1 nF)

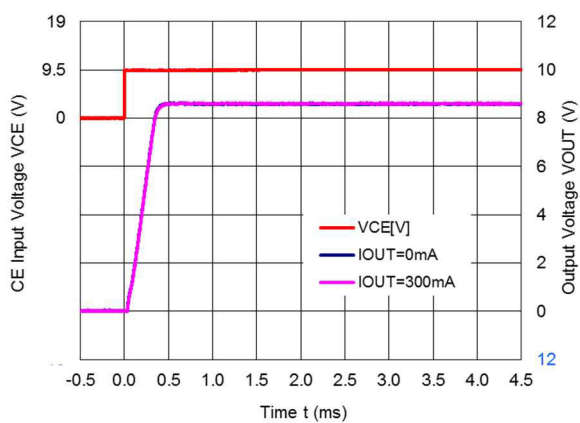

R1518x851F (C2 = 0.1 μF, CD = 1 nF)

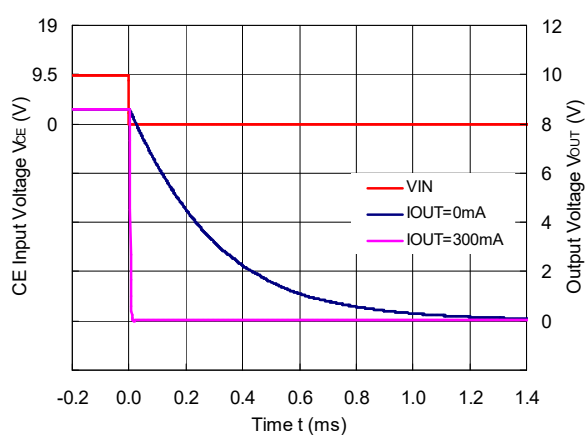

11) Inrush Current Prevention Circuit ($T_a = 25^\circ\text{C}$, $I_{OUT} = 1 \text{ mA}$)

R1518x25xB/D, R1518x001C

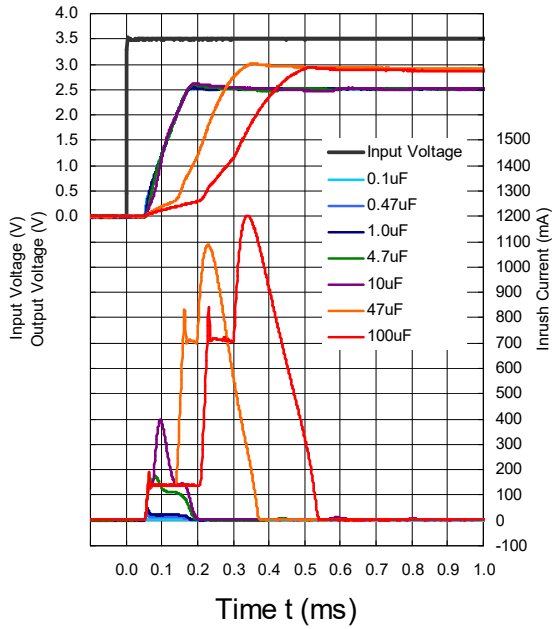

R1518x33xB/D

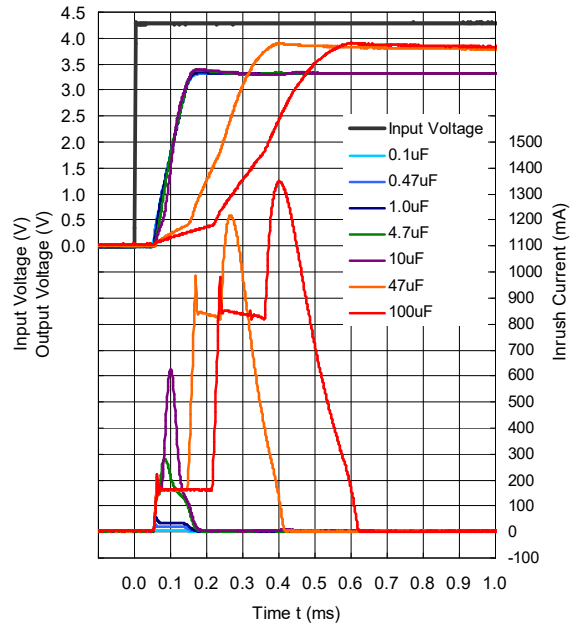

R1518x50xB/D

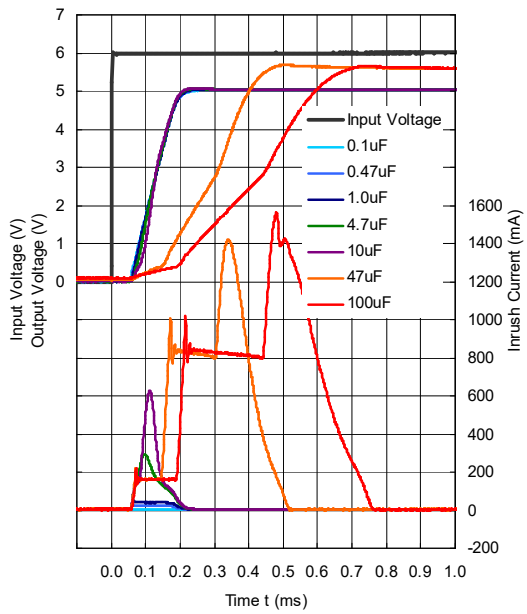

R1518x85xB/D

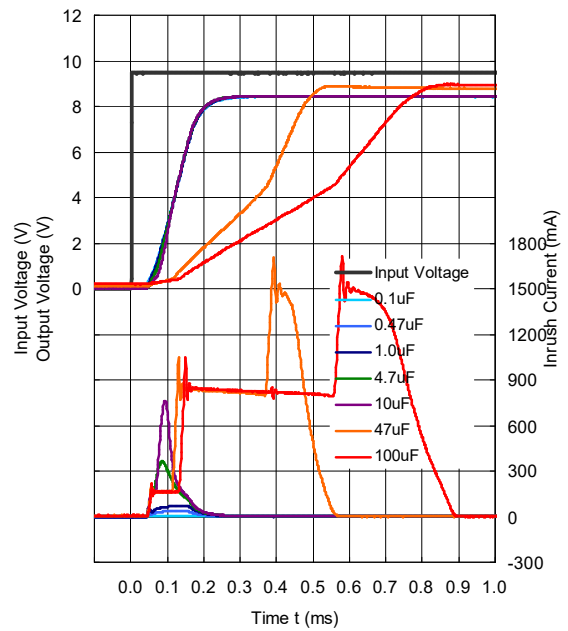

R1518x25xE/F ($C_D = 10\text{ nF}$)

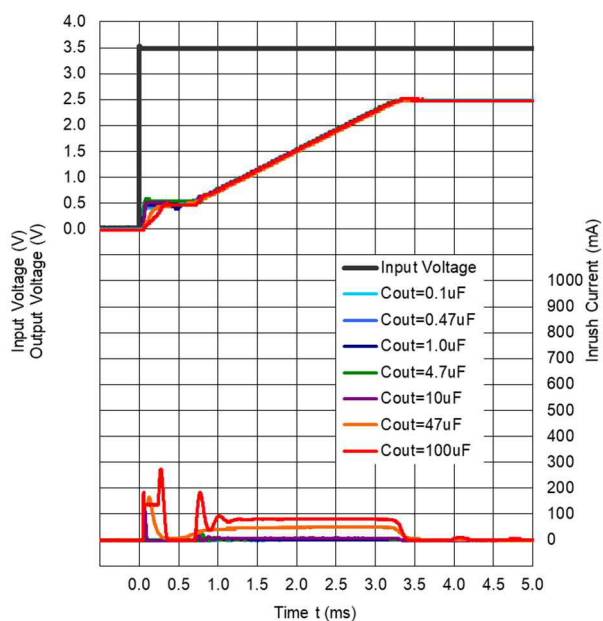

R1518x33xE/F ($C_D = 10\text{ nF}$)

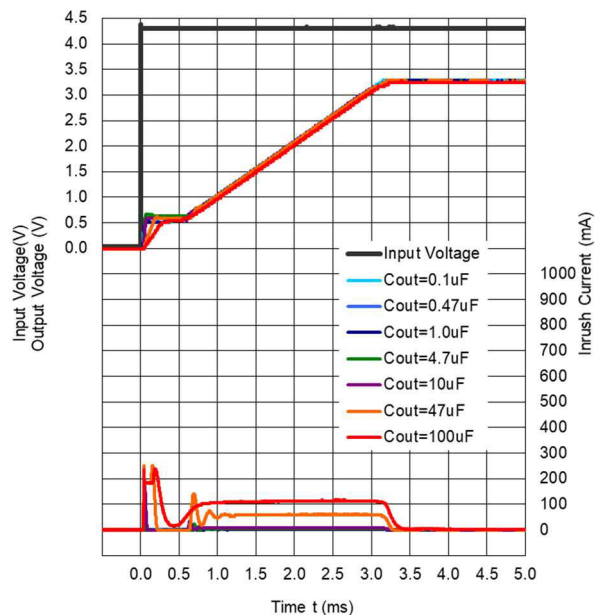

R1518x50xE/F ($C_D = 10\text{ nF}$)

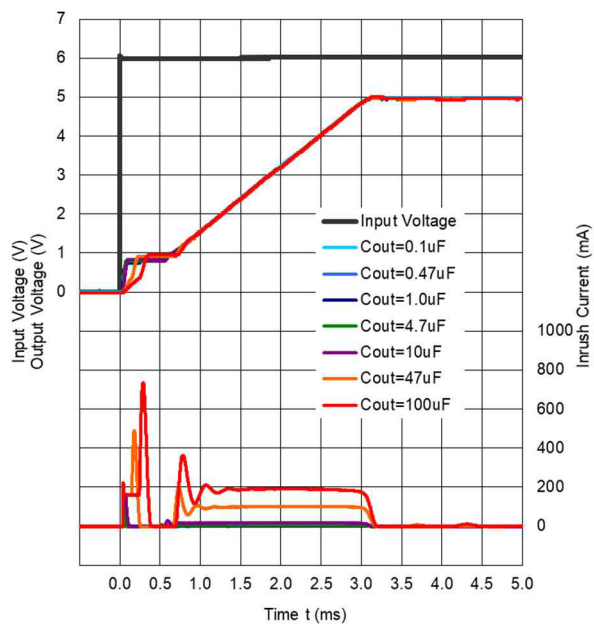

R1518x85xE/F ($C_D = 10\text{ nF}$)

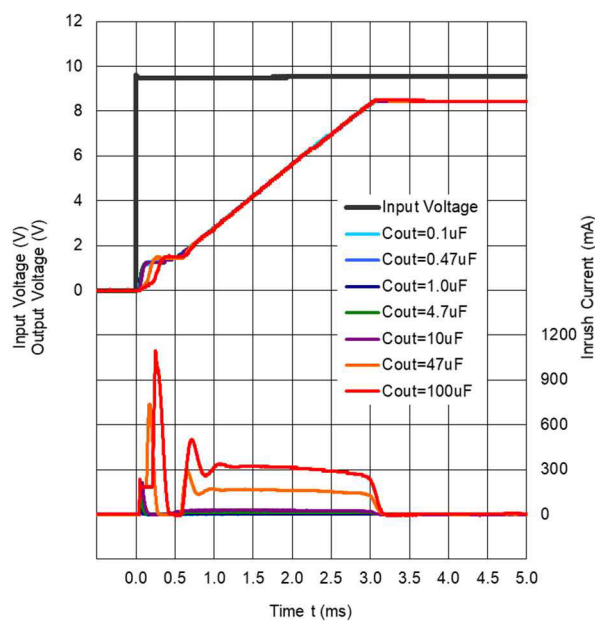

The power dissipation of the package is dependent on PCB material, layout, and environmental conditions. The following measurement conditions are based on JEDEC STD. 51-7.

Measurement Conditions

Item	Measurement Conditions
Environment	Mounting on Board (Wind Velocity = 0 m/s)
Board Material	Glass Cloth Epoxy Plastic (Four-Layer Board)
Board Dimensions	76.2 mm × 114.3 mm × 0.8 mm
Copper Ratio	Outer Layer (First Layer): Less than 95% of 50 mm Square Inner Layers (Second and Third Layers): Approx. 100% of 50 mm Square Outer Layer (Fourth Layer): Approx. 100% of 50 mm Square
Through-holes	φ 0.3 mm × 28 pcs

Measurement Result

(Ta = 25°C, Tjmax = 125°C)

Item	Measurement Result
Power Dissipation	2700 mW
Thermal Resistance (θja)	θja = 37°C/W
Thermal Characterization Parameter (ψjt)	ψjt = 7°C/W

θja: Junction-to-Ambient Thermal Resistance

ψjt: Junction-to-Top Thermal Characterization Parameter

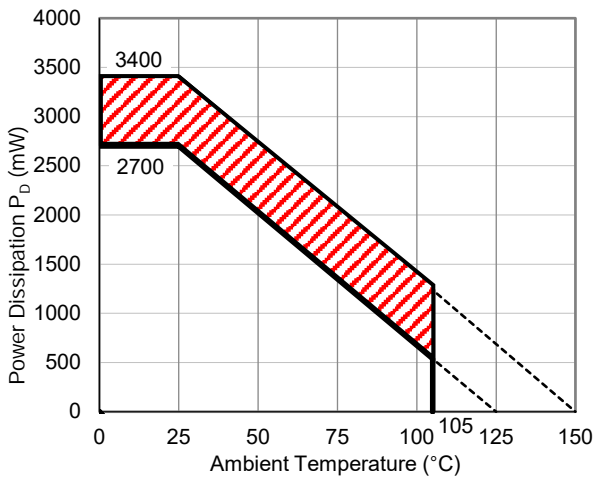

Power Dissipation vs. Ambient Temperature

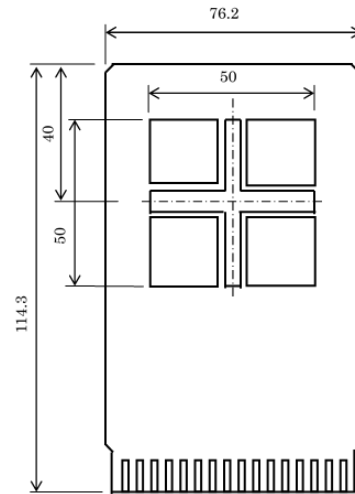

Measurement Board Pattern

The above graph shows the power dissipation of the package at Tjmax = 125°C and Tjmax = 150°C. Operating the device in the hatched range might have a negative influence on its lifetime. The total hours of use and the total years of use must be limited as follows:

Total Hours of Use	Total Years of Use (4 hours/day)
13,000 hours	9 years

PACKAGE DIMENSIONS

HSOP-6J

DM-HSOP-6J-JE-A

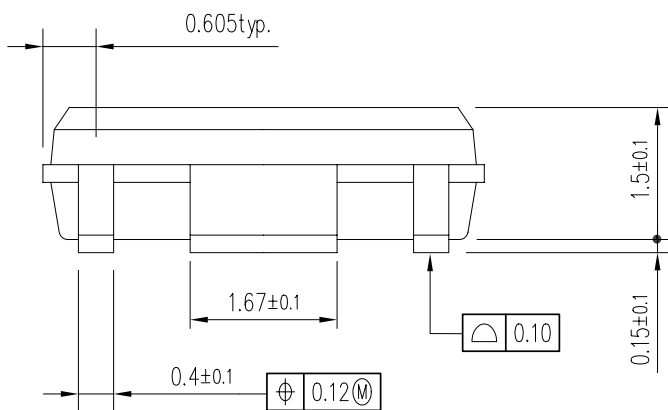
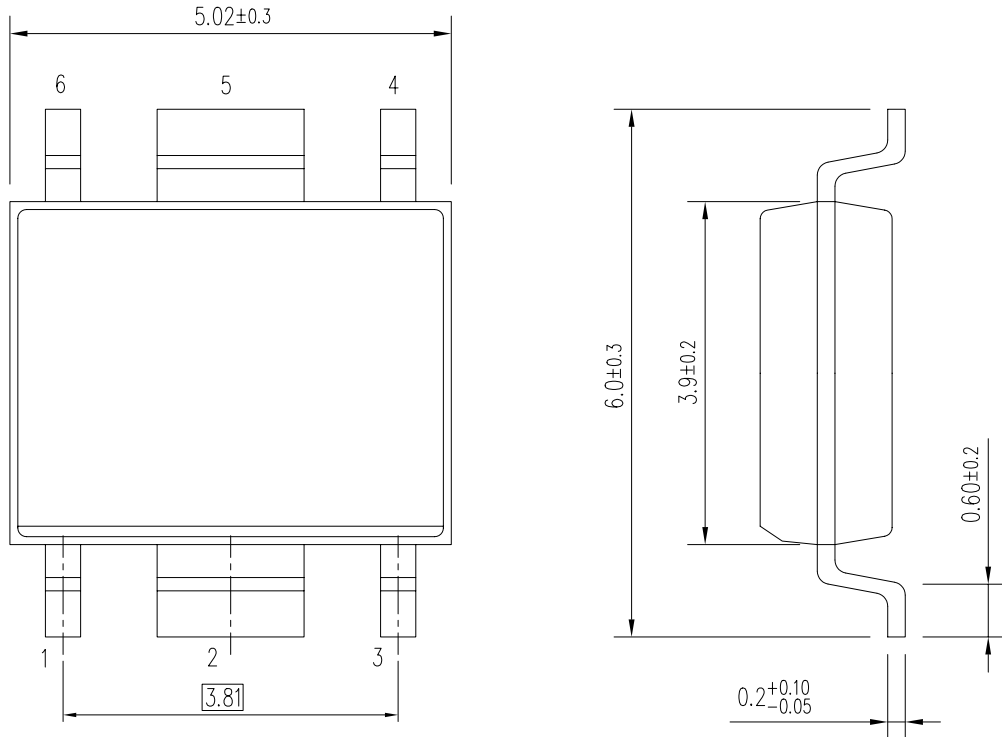

UNIT: mm

HSOP-6J Package Dimensions

①②③④: Product Code ... Refer to “R1518S MARK SPECIFICATION TABLE (HSOP-6J)”

⑤⑥: Lot Number ... Alphanumeric Serial Number

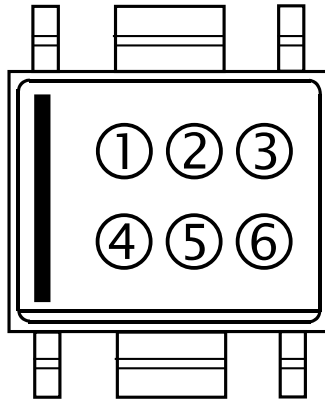

HSOP-6J Part Markings

NOTICE

There can be variation in the marking when different AOI (Automated Optical Inspection) equipment is used. In the case of recognizing the marking characteristic with AOI, please contact our sales or our distributor before attempting to use AOI.

R1518S MARK SPECIFICATION TABLE (HSOP-6J)

R1518Sxx1B

Product Name	①②③④	V _{SET}
R1518S251B	W 1 2 5	2.5 V
R1518S331B	W 1 3 3	3.3 V
R1518S341B	W 1 3 4	3.4 V
R1518S501B	W 1 5 0	5.0 V
R1518S601B	W 1 6 0	6.0 V
R1518S851B	W 1 8 5	8.5 V
R1518S901B	W 1 9 0	9.0 V

R1518S001C

Product Name	①②③④	V _{SET}
R1518S001C	W 2 0 1	-

R1518Sxx1D

Product Name	①②③④	V _{SET}
R1518S251D	W 3 2 5	2.5 V
R1518S331D	W 3 3 3	3.3 V
R1518S341D	W 3 3 4	3.4 V
R1518S501D	W 3 5 0	5.0 V
R1518S601D	W 3 6 0	6.0 V
R1518S851D	W 3 8 5	8.5 V
R1518S901D	W 3 9 0	9.0 V

R1518Sxx1E

Product Name	①②③④	V _{SET}
R1518S251E	W 4 2 5	2.5 V
R1518S331E	W 4 3 3	3.3 V
R1518S341E	W 4 3 4	3.4 V
R1518S501E	W 4 5 0	5.0 V
R1518S601E	W 4 6 0	6.0 V
R1518S851E	W 4 8 5	8.5 V
R1518S901E	W 4 9 0	9.0 V

R1518Sxx1F

Product Name	①②③④	V _{SET}
R1518S251F	W 5 2 5	2.5 V
R1518S331F	W 5 3 3	3.3 V
R1518S341F	W 5 3 4	3.4 V
R1518S501F	W 5 5 0	5.0 V
R1518S601F	W 5 6 0	6.0 V
R1518S851F	W 5 8 5	8.5 V
R1518S901F	W 5 9 0	9.0 V

The power dissipation of the package is dependent on PCB material, layout, and environmental conditions. The following measurement conditions are based on JEDEC STD. 51-7.

Measurement Conditions

Item	Measurement Conditions
Environment	Mounting on Board (Wind Velocity = 0 m/s)
Board Material	Glass Cloth Epoxy Plastic (Four-Layer Board)
Board Dimensions	76.2 mm × 114.3 mm × 0.8 mm
Copper Ratio	Outer Layer (First Layer): Approx.95% of 50 mm Square Inner Layers (Second and Third Layers): Approx. 100% of 50 mm Square Outer Layer (Fourth Layer): Approx. 100% of 50 mm Square
Through-holes	φ 0.3 mm × 21 pcs

Measurement Result

(Ta = 25°C, Tjmax = 125°C)

Item	Measurement Result
Power Dissipation	3800 mW
Thermal Resistance (θja)	θja = 26°C/W
Thermal Characterization Parameter (ψjt)	ψjt = 7°C/W

θja: Junction-to-Ambient Thermal Resistance

ψjt: Junction-to-Top Thermal Characterization Parameter

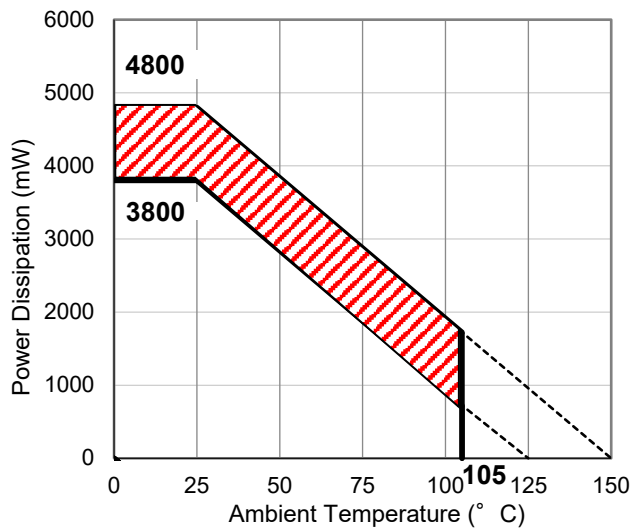

Power Dissipation vs. Ambient Temperature

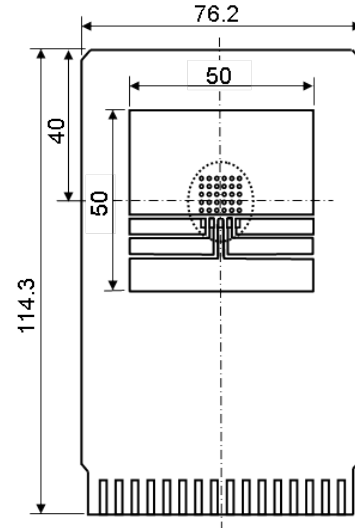

Measurement Board Pattern

The above graph shows the power dissipation of the package at Tjmax = 125°C and Tjmax = 150°C. Operating the device in the hatched range might have a negative influence on its lifetime. The total hours of use and the total years of use must be limited as follows:

Total Hours of Use	Total Years of Use (4 hours/day)
13,000 hours	9 years

①②③④⑤⑥⑦⑧: Product Code ... Refer to "R1518J MARK SPECIFICATION TABLE (TO-252-5-P2)"
⑨⑩: Lot Number ... Alphanumeric Serial Number

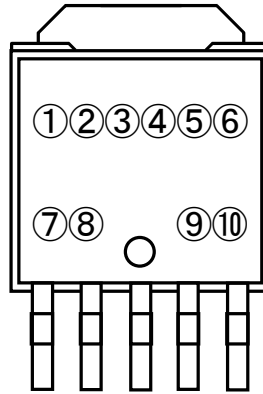

TO-252-5-P2 Part Markings

NOTICE

There can be variation in the marking when different AOI (Automated Optical Inspection) equipment is used. In the case of recognizing the marking characteristic with AOI, please contact our sales or our distributor before attempting to use AOI.

R1518J MARK SPECIFICATION TABLE (TO-252-5-P2)

Note: ⑧ Underbar indicates a blank

R1518Jxx1B

Product Name	①②③④⑤⑥⑦⑧	V _{SET}
R1518J251B	L 1 J 2 5 1 B _	2.5 V
R1518J331B	L 1 J 3 3 1 B _	3.3 V
R1518J341B	L 1 J 3 4 1 B _	3.4 V
R1518J501B	L 1 J 5 0 1 B _	5.0 V
R1518J601B	L 1 J 6 0 1 B _	6.0 V
R1518J851B	L 1 J 8 5 1 B _	8.5 V
R1518J901B	L 1 J 9 0 1 B _	9.0 V

R1518J001C

Product Name	①②③④⑤⑥⑦⑧	V _{SET}
R1518J001C	L 2 J 0 0 1 C _	-

R1518Jxx1D

Product Name	①②③④⑤⑥⑦⑧	V _{SET}
R1518J251D	L 3 J 2 5 1 D _	2.5 V
R1518J331D	L 3 J 3 3 1 D _	3.3 V
R1518J341D	L 3 J 3 4 1 D _	3.4 V
R1518J501D	L 3 J 5 0 1 D _	5.0 V
R1518J601D	L 3 J 6 0 1 D _	6.0 V
R1518J851D	L 3 J 8 5 1 D _	8.5 V
R1518J901D	L 3 J 9 0 1 D _	9.0 V

R1518Jxx1E

Product Name	①②③④⑤⑥⑦⑧	V _{SET}
R1518J251E	L 4 J 2 5 1 E _	2.5 V
R1518J331E	L 4 J 3 3 1 E _	3.3 V
R1518J341E	L 4 J 3 4 1 E _	3.4 V
R1518J501E	L 4 J 5 0 1 E _	5.0 V
R1518J601E	L 4 J 6 0 1 E _	6.0 V
R1518J851E	L 4 J 8 5 1 E _	8.5 V
R1518J901E	L 4 J 9 0 1 E _	9.0 V

R1518Jxx1F

Product Name	①②③④⑤⑥⑦⑧	V _{SET}
R1518J251F	L 5 J 2 5 1 F _	2.5 V
R1518J331F	L 5 J 3 3 1 F _	3.3 V
R1518J341F	L 5 J 3 4 1 F _	3.4 V
R1518J501F	L 5 J 5 0 1 F _	5.0 V
R1518J601F	L 5 J 6 0 1 F _	6.0 V
R1518J851F	L 5 J 8 5 1 F _	8.5 V
R1518J901F	L 5 J 9 0 1 F _	9.0 V



1. The products and the product specifications described in this document are subject to change or discontinuation of production without notice for reasons such as improvement. Therefore, before deciding to use the products, please refer to our sales representatives for the latest information thereon.
2. The materials in this document may not be copied or otherwise reproduced in whole or in part without prior written consent of our company.
3. Please be sure to take any necessary formalities under relevant laws or regulations before exporting or otherwise taking out of your country the products or the technical information described herein.
4. The technical information described in this document shows typical characteristics of and example application circuits for the products. The release of such information is not to be construed as a warranty of or a grant of license under our company's or any third party's intellectual property rights or any other rights.
5. The products listed in this document are intended and designed for use as general electronic components in standard applications (office equipment, telecommunication equipment, measuring instruments, consumer electronic products, amusement equipment etc.). Those customers intending to use a product in an application requiring extreme quality and reliability, for example, in a highly specific application where the failure or misoperation of the product could result in human injury or death (aircraft, spacevehicle, nuclear reactor control system, traffic control system, automotive and transportation equipment, combustion equipment, safety devices, life support system etc.) should first contact us.
6. We are making our continuous effort to improve the quality and reliability of our products, but semiconductor products are likely to fail with certain probability. In order to prevent any injury to persons or damages to property resulting from such failure, customers should be careful enough to incorporate safety measures in their design, such as redundancy feature, fire containment feature and fail-safe feature. We do not assume any liability or responsibility for any loss or damage arising from misuse or inappropriate use of the products.
7. Anti-radiation design is not implemented in the products described in this document.
8. The X-ray exposure can influence functions and characteristics of the products. Confirm the product functions and characteristics in the evaluation stage.
9. WLCSP products should be used in light shielded environments. The light exposure can influence functions and characteristics of the products under operation or storage.
10. There can be variation in the marking when different AOI (Automated Optical Inspection) equipment is used. In the case of recognizing the marking characteristic with AOI, please contact our sales or our distributor before attempting to use AOI.
11. Please contact our sales representatives should you have any questions or comments concerning the products or the technical information.



Nisshinbo Micro Devices Inc.

Official website

<https://www.nisshinbo-microdevices.co.jp/en/>

Purchase information

<https://www.nisshinbo-microdevices.co.jp/en/buy/>

